



IoT-Enabled Energy-Efficient Smart Home System Using RTOS

Aiman Zulkifli¹, Prof. Roslan Ismail², Prof. Siti Hamidah³

¹Research Scholar, School of Computing, Universiti Teknologi MARA, Malaysia

²Professor, Faculty of Computer Science, Universiti Malaysia Pahang, Malaysia

³Associate Professor, Department of Information Systems, Universiti Tun Hussein Onn Malaysia, Malaysia

Abstract— The features of Android like its Connectivity , Java support has been widely used in many applications . This paper presents the design and implementation of a low cost yet compact and wide range Android smart phone based home automation system. This project is based on the popular Arduino prototyping board where the electrical appliances are interfaced with ports of the board . In order to make the system energy efficient , we've used some sensors to analyse the current environmental conditions so as to provide energy efficiency . To handle these various operations we have integrated a popular RTOS, the scmRTOS, which has a very small footprint on the microcontroller. An Android application which has been developed for Android devices is used for interation between user and system .A typical wireless home automation system allows one to control house hold appliances from a centralized control unit which is wireless. The project demonstrates a system that can be integrated as a single portable unit and allows one to wirelessly control lights, fans, water sprinkler etc. and turn on or off any appliance , get the status of different sensors and take decision accordingly.The project also deals with contolling the fan speed, light intensity by limiting the amount of current supplied to appliances. The medium used for sending and receiving of commands is WiFi which is again of the feature of Android system and at the control unit XBee transceiver is used for same purpose. The remote system receives the commands through XBee transceiver and performs the request function. The sensors unit is capable of detecting chnages in environmental conditions like temperature, soil moisture and can accordingly turn on or off appliances such as lights and fans and in the meantime send its status back to base station.

Keywords— Home automation, Smartphone, WiFi,Arduino.

I. INTRODUCTION

Home automation is automating appliaces of the home, housework or household activity. It may include a centralized control of lighting, HVAC (heating, ventilation and air conditioning), appliances, and other systems, to provide improved convenience, comfort, energy efficiency,security and safety. This concept has been around for a long time and products have been in the market for decades, yet none of it was cheap and effective enough to become a widely recognized product.Home automation for the elderly and disabled can provide increased quality of life for persons who might otherwise require caregivers or institutional care. It can also provide a remote interface to home appliances or the automation system itself, via telephone line, wireless transmission or the internet, to provide control and monitoring via a smart phone or web browser. This paper will describe the approach which we are implementing to control various home appliances with Android smart phone.

With the aquisition of Anroid Inc in 2005 and promotion of Android as a Smart Phone Operating System by Google Inc, SmartPhones have become more popular with every passing year all around the world. This mass adoption of Smart Phones has fuelled a demand for applications both soft and hard. Today, SmartPhones are more than just Phones, they're now the main Human Interaction Devices(HIDs) and users thus want to control/accomplish most of their tasks from their Smart Phones rather than conventional ways. The many wireless protocols that come embedded on a SmartPhone has introduced a wireless lifestyle reliving people from the "wired" cable chaos [1].

RTOS is used on the recieving mircocontroller to initiate the various processes required for controlling an appliance.An AC fan/motor speed can be controlled using the delayed phase angle firing method.XBee Wi-Fi modules provide simple serial to IEEE802.11 connectivity.As a member of the XBee family, the XBee Wi-Fi combines hardware with software for a complete modular solution. XBee Wi-Fi modulesare designed to communicate with access points in existing 802.11infrastructures. Developers can use AT and API commands for advanced configuration options.Sensors are interfaced to make the microcontroller aware of the

environment and take corresponding action when Eco mode is on , which would help in saving energy when not required.

II. PROBLEM DEFINITION

The purpose of this project is to design wireless Home Automation System controlled by Smartphones and making it Energy Efficient with the use of sensors. The objectives for this project are to Interface sensors with the Arduino board and calibrate them to detect environmental changes, analyze the data acquired by the sensors and take appropriate measures, interfacing of Xbee modules for trans-reception, sending data between Arduino and Smartphone using Xbee wifi module , developing an Android application which will simply the task. System used for this project consists of following components:-

- Smartphone(Any smartphone with WiFi)
- Xbee Wifi Module
- Arduino Uno Board
- LM 35 temperature sensor
- A simple moisture sensor
- LDR
- MOC 3021 (Opto-isolator)
- BT 136 (Triac)
- Zero Cross Detector

III. OBJECTIVES OF PROJECT

The primary design objective of the Home Automation system is to control home appliances wirelessly. But while controlling the appliances there are two modes of operation provided to the user. It includes normal mode and energy efficient mode.

For Energy efficiency mode, the sensors like light sensor, temperature sensor are interfaced with micro-controller. The light dependant resistor for light sensing and LM 35 is used for temperature sensing . Which will continuously sense the presence of light and tempreture of surrounding to take necessary action. Along with these sensors soil moisture senosr is also interfaced with micro-controller which will sense the moisture level of soil to turn on or off the water sprinkler. Data from these sensors is used for controlling the appliances for reducing energy consumption in energy efficient mode.

Another objective of this project is to create an android application. This app will help user to send their instructions by using inbuilt WiFi of smart phone. The purpose of using WiFi system is to increase range of system.

scmRTOS will allow us to run multiple tasks in parallel allowing for real time execution and context switching. The Android application developed in Java inquires for available Wi- Fi devices in the vicinity and connects to our module if it's available for sending commands

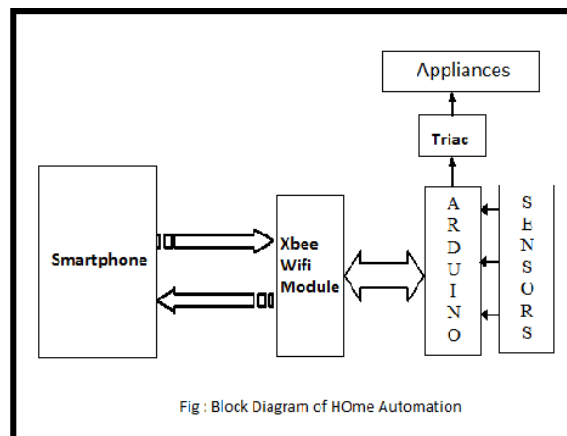

Fig1: Block diagram of system

The appliances can be controlled by using the application developed for android. The data is sent to the Xbee wifi module by wifi inbuilt in the mobile phone. The xbee wifi module receives this and gives it to the microcontroller. The microcontroller at the appliance side processes it and takes the corresponding action. For continuous energy efficiency the receiving microcontroller also has various sensors attached to it. The data from these sensors is used to control the appliances for reducing power consumption.

SR. No.	Component of the	Details of the component
1)	Smart phone	Any smart phone with Android OS and inbuilt WiFi.
2)	Xbee WiFi	*UART up to 1Mbps *Indoor range – 30 meters *Outdoor Range – 100 meters *Freq. Band – 0 to 2.4 GHz
3)	ATmega 328p	*No. of pins – 40 *Flash Memory –32KB *SRAM size – 2 KB *EEPROM –1KB *Operating voltage – 5 V. * Operating Temp - -40 to 85 C. *RISC Architecture.
4)	LM 35	*Supply voltage –5V *OperatingTemp– -55 to 150 C
5)	MOC 3021 Opto-isolater	*High isolation -7500 V peak *Input diode reverse voltage - 3V *Input diode reversecurrent, continous – 50 mA *Output repetitive peak off voltage - 400 V

6)	BT 136 Triac	*Repetitive peak off-state voltage -600 V *RMS on-state current -4 A *Non-repetitive peak on-state current - 25 A
----	-----------------	--

Table 1: Component Specifications

IV. MODULE WORKING

The idea of working module is given below :-

For Normal Mode:

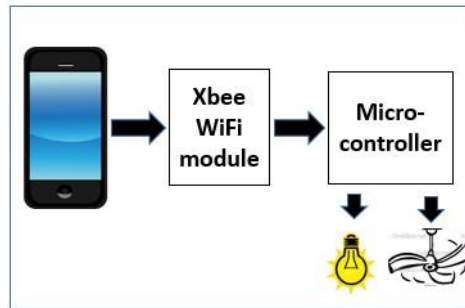

Fig2: Normal mode

In normal mode of operation user can simply control the appliances by sending instructions through their smart phone. Xbee module at control unit will receive the instruction and send it to Arduino board through serial transmission. Arduino board will take required action as per the instructions. The appliances are then turned on or off through Triac circuitary.

For Energy efficiency Mode:

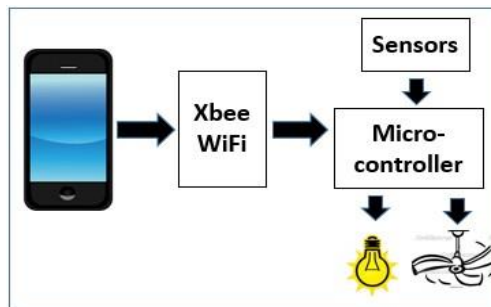

Fig3: Energy efficient Mode

For Energy efficiency mode, the sensors like light sensor, temperature sensor are interfaced with microcontroller. The data from these sensors is used for controlling the appliances for reducing energy consumption. According to the data triac circuitary will adjust the amount of current supplied to appliances. Which will help our system to reduce unnecessary energy consumption and will achieve the goal of energy efficiency in certain amount. Soil moisture sensor will help us to supply proper amount of water to plants according to moisture level of soil.

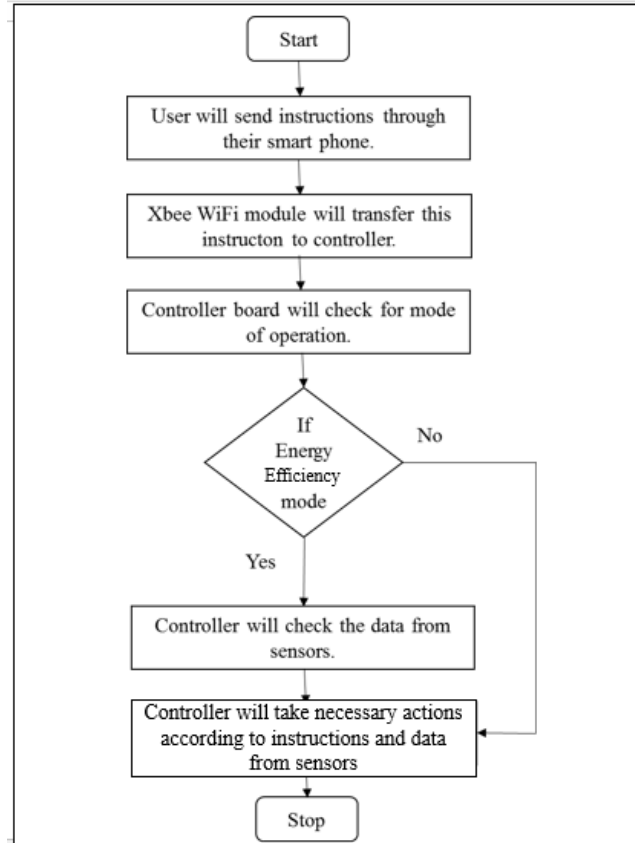

Fig4: Flowchart of system

V. CONCLUSION

This project is based on the simple idea of controlling home appliances using mobile application and to provide energy efficiency in certain amount. Due to use of ISM band frequency the data transfer is fast and range is also increased. Sensors and RTOS provide good utilization of energy while use of Smartphone application make the system easily controllable with a rich graphical user interface.

REFERENCES

- [1] Neng- Shiang Liang; Li-Chen Fu; Chao-Lin Wu. "An integrated, flexible, and Internet-based control architecture for home automation system in the internet era". Proceedings ICRA '02. IEEE International Conference on Robotics and Automation, Vol. 2, pp.1101-1106, 2002.
- [2] N. Sriskanthan and Tan Karand. "Bluetooth Based Home Automation System". Journal of Microprocessors and Microsystems, Vol. 26, pp.281-289, 2002.
- [3] Muhammad Izhar Ramli, Mohd Helmy Abd Wahab, Nabihah, "TOWARDS SMART HOME: CONTROL ELECTRICAL DEVICES ONLINE" ,Nornabihah Ahmad International Conference on Science and Technology: Application in Industry and Education (2006).
- [4] Al-Ali, Member, IEEE & M. AL-Rousan, "Java-Based Home Automation System R." IEEE Transactions on Consumer Electronics, Vol. 50, No. 2, MAY 2004
- [5] Pradeep.G, B.Santhi Chandra, M.Venkateswarao, "Ad-Hoc Low Powered 802.15.1 Protocol Based Automation System for Residence using Mobile Devices", Dept.of ECE, K L University, Vijayawada, Andhra Pradesh, India IJCST Vo 1. 2, SP 1, December 2011
- [6] E. Yavuz, B. Hasan, I. Serkan and K. Duygu. "Safe and Secure PIC Based Remote Control Application for Intelligent Home". International Journal of Computer Science and Network Security, Vol. 7, No. 5, May 2007.
- [7] Amul Jadhav, S. Anand, Nilesh Dhangare, K.S. Wagh "Universal Mobile Application Development (UMAD) On Home Automa Marathwada Mitra Mandal's Institute of Technology, University of Pune, India Network and Complex

Systems ISSN 2224-610X (Paper) ISSN 2225-0603 (Online) Vol 2, No.2, 2012

- [8] Rana, Jitendra Rajendra and Pawar, Sunil N., Zigbee Based Home Automation (April 10, 2010). Available at SSRN: <http://ssrn.com/abstract=1587245> or <http://dx.doi.org/10.2139/ssrn.1587245>
- [9] R.Piyare, M.Tazil” Bluetooth Based Home Automation System Using Cell Phone”, 2011 IEEE 15th International Symposium on Consumer Electronics [10] <http://googleblog.blogspot.in/2011/05/android-momentum-mobile-and-more-at.html>
- [11] <http://developer.android.com/about/index.html>
- [12] <http://research.microsoft.com/en-us/projects/homeos/>
- [13] <http://source.android.com/tech/accessories/index.html>
- [14] <http://developer.android.com/guide/topics/connectivity/usb/accessory.html#manifest>
- [15] <http://arduino.cc/en/Main/ArduinoBoardADK>
- [16] Official page for scmRTOS development(<http://scmrts.sourceforge.net/ScmRTOS>)
- [17].Y.Usha Devi 1, II M.Tech, Wireless Home Automation System Using ZigBee, International Journal of Scientific & Engineering Research ,Volume 3, Issue 8, August-2012 ISSN 2229-5.