

Harmonic Mitigation Using Synchronous Reference Frame Theory: A Simulation Study

Quoc Dang¹, Prof. Minh Truong², Prof. Phuc Hoang³

¹Research Scholar, Computer Science Dept., Vietnam National University Ho Chi Minh City, Vietnam

²Professor, School of Computing, Hanoi Open University, Vietnam

³Associate Professor, Faculty of Engineering, Duy Tan University, Vietnam

Abstract - This paper conceptualizes shunt active power filter (SAPF) using synchronous-reference-frame (SRF) theory to mitigate the harmonics present in the power system. The shunt active power filter injects a suitable compensating current at a point called point of common coupling (PCC) so that the harmonics present in the line are cancelled out and sinusoidal nature of voltage and current waveforms are restored. A three phase current controlled voltage source inverter (VSI) with DC link capacitor across it is used as an active filter. Synchronous reference frame (SRF) algorithm is used to extract the harmonic components. Hysteresis band current control (HBCC) technique is used for the generation of firing pulses to the inverter. The system is simulated using MATLAB/Simulink and results are discussed.

Keywords- HBSS, PCC, SRF, SAPF, VSI.

I. INTRODUCTION

The nonlinear loads like UPS system, AC & DC Drive, Lighting ballasts, Arcing devices, Rotating machines, Phase controller, AC regulator and Static power converters such as single-phase and three phase rectifiers, thyristor converters and a large number of low-power electronic-based appliances that generate considerable disturbances in the AC mains. Current harmonics, which may also be asymmetric, cause voltage drops across the supply network impedance as well as other undesirable phenomena (e.g. shunt and series resonance, flicker) resulting in distorted supply voltages, and hence a reduction in the supply voltage quality.

The presence of harmonics in the power lines results in greater power losses in distribution, can cause noise problems in communication systems and sometimes cause failure of operation of electronic equipment, which have higher sensitivity because of the inclusion of microelectronic control systems. These systems are low powered devices and thus a little noise can be significant. These are the reasons which make the power quality issue one of the most concerned issues as far the end user is concerned.

The active harmonic filters have the following multiple functions: harmonic filtering, reactive-power control for power factor correction, damping, isolation and voltage regulation, load balancing, voltage flicker reduction and/or their combinations. Most active filters can use either voltage-source pulse width-modulated (PWM) converter equipped with a dc capacitor or current-source PWM converter equipped with a dc inductor. The voltage source converter is more suitable than the current-source converter in terms of cost, physical size and efficiency.

The reference signals are transformed from a-b-c stationary frame to 0-d-q rotating frame. Using the PI controller, the reference signals in 0-d-q rotating frame are controlled to get the desired reference signals for pulse width modulation. The Hysteresis band current control technique is used for the generation of firing pulses to the voltage source converter.

II. SHUNT ACTIVE FILTER

Shunt active filters generally consist of two main blocks:

- The PWM converter
- The active filter controller

The PWM converter is meant for power processing in synthesizing the compensating current that should be drawn from the power system. The active filter controller is responsible for signal processing in determining in real time instantaneous compensating current references, which are continuously passed to the PWM converter.

Figure 1 shows the basic configuration of a shunt active filter for harmonic current compensation of a specific load. It contains a voltage source converter with a PWM current controller and an active filter controller. The shunt active filter continuously sensing the load current i_L , and calculating the instantaneous values of the compensating current reference i_C for the PWM converter.

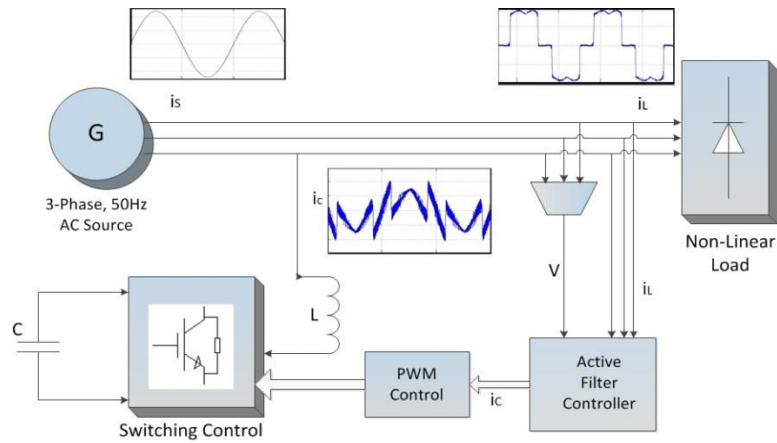

Figure 1. Basic configuration of a shunt active filter.

Synchronous Reference Frame Theory:

This method of reference current generation is developed in time domain based reference current generation. This theory is extensively used due to simplicity of calculations and uses only algebraic calculation. The three phase load current (i_{La} , i_{Lb} , i_{Lc}) are transformed into the two instantaneous active (i_d) and reactive (i_q) components in a rotating synchronous frame with the positive sequence of the system voltage. The basic working principle of SRF method uses a direct (d-q) and inverse (d-q) park transformation method, which allow the evaluation of a specific harmonic component of the input signals.

The reference frame transformation is evaluated by converting a three-phase a-b-c stationary reference frame system to the synchronous reference frame system d-q-0 whose two-phase direct axis (d) and quadratic axis (q) component rotate in space at synchronous speed ω_e , which is the angular electrical speed of the rotating magnetic field of the three phase supply given by $\omega_e = 2\pi f_s$, where f_s is the frequency of the supply. If the Θ is the transformation angle, then the current transformation from a-b-c to d-q-0 frame is calculated as

$$\begin{bmatrix} i_d \\ i_q \\ i_0 \end{bmatrix} = \sqrt{\frac{2}{3}} \begin{bmatrix} \cos\theta & \cos(\theta - \frac{2\pi}{3}) & \cos(\theta + \frac{2\pi}{3}) \\ -\sin\theta & -\sin(\theta - \frac{2\pi}{3}) & -\sin(\theta + \frac{2\pi}{3}) \\ \frac{1}{\sqrt{2}} & \frac{1}{\sqrt{2}} & \frac{1}{\sqrt{2}} \end{bmatrix} \begin{bmatrix} i_a \\ i_b \\ i_c \end{bmatrix}$$

$$\text{Where } \Theta(t) = \int_0^t \omega_e(t) dt + \theta_0$$

The sine and cosine functions help to maintain the synchronization with supply voltage and current. The d-q transformation output signals are dependent on the load current and the performance of the PLL. The PLL circuit provides the rotation speed of the rotating reference frame. The $i_d - i_q$ currents are sent through low pass filter for filtering the harmonic components of the load current, which allow only fundamental frequency components. The LPF is second order Butterworth filter used for eliminating the higher order harmonics. Figure 2 shows the basic block diagram of SRF based current control strategy.

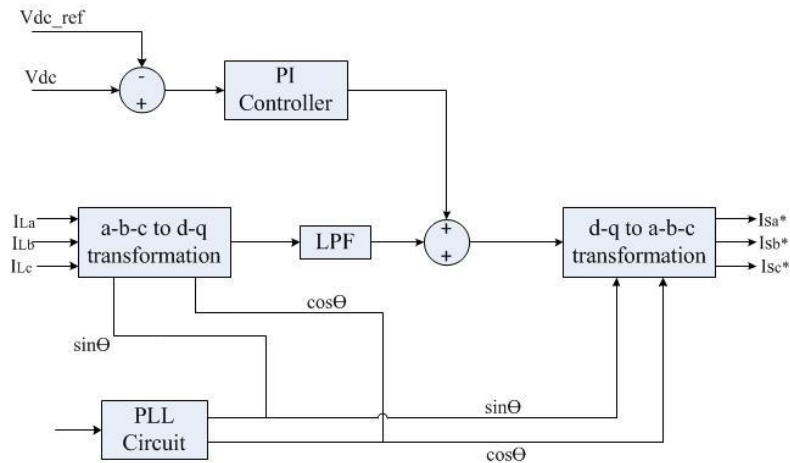

Figure 2. Block Diagram of SRF based Current Control Strategy

Proportional Integral (PI) controller:

The PI controller is an important part for the SAPF. PI focuses on the difference (error) between the process variable and the set point value. PI controller algorithm involves two separate parameters; the proportional and Integral. The proportional value determines the reaction to the current error; the integral determines the reaction based on the sum of the recent errors. The weighted sum of these two actions is used to adjust the process of the plant. By tuning the two constants in the PI controller algorithm, the PI controller can provide control action designed for specific process requirements.

Hysteresis Band Current Control:

The hysteresis band current control (HBCC) method is used for pulse generation in current controlled VSC. This method provides good stability, very fast in response, provide good accuracy and easy to implementation. In this method, knowledge of load parameters is not required. The HBCC method employed in an active filter for the control of the line current is shown in figure 3. It consists of a hysteresis band surrounding the generated error current. The current error is obtained by subtracting the actual filter current from the reference current. The reference current is obtained using SRF method. The error signal is fed to the relay with the desired hysteresis band to obtain the switching pulse for the converter.

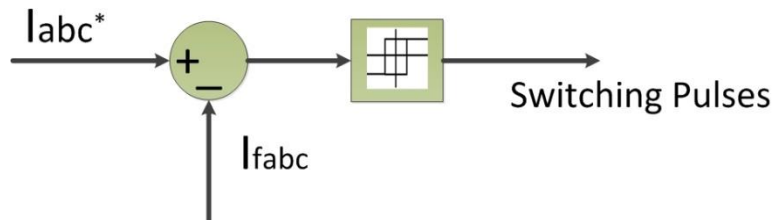

Figure 3. Hysteresis band current controller

III. Simulation Results

Figure 4 shows the Matlab/Simulink model of SAPF based on SRF Theory. The SRF-based control algorithm for APF is simulated by Matlab / Simulink software. figure5 shows the simulation diagram of SRF based current control strategy. The APF system parameters used in this study are given in Table 1. In the simulation studies, the results are specified before and after the operation of the APF. The THD levels are given before and after filter operation. The obtained results show that the proposed control method allows THD level of 3.77%. In the proposed SRF-based control algorithm, the load current and source voltages are measured to calculate the shunt APF reference currents.

The current and voltage with distortion is compensated to generate the sinusoidal waveforms at PCC. Before compensation, the THD level of the source current was 23.94%; after compensation, the THD level of the source current is approximately 3.77%.

The obtained simulation results show that the proposed SAPF control technique has better compensation performance.

Table 1 SAPF simulation parameters

	Parameters		Value
Source	Voltage	V_{Sabc}	440V _{rms}
	Frequency	f	50Hz
Load	3-phase AC Line Inductance	L_{Labc}	3.0mH
	3-phase DC Inductance	L_{dc}	25.0mH
	3-phase DC Resistor	R_{dc}	50.0Ω
Dc Link	Voltage	V_{DC}	650V
	Capacitor	C	2200μF
Shunt APF	Switching Frequency	f_{pwm}	~10kHz
	Filter Resistor	R_{Cabc}	10Ω
	Filter Capacitor	C_{Cabc}	10μF

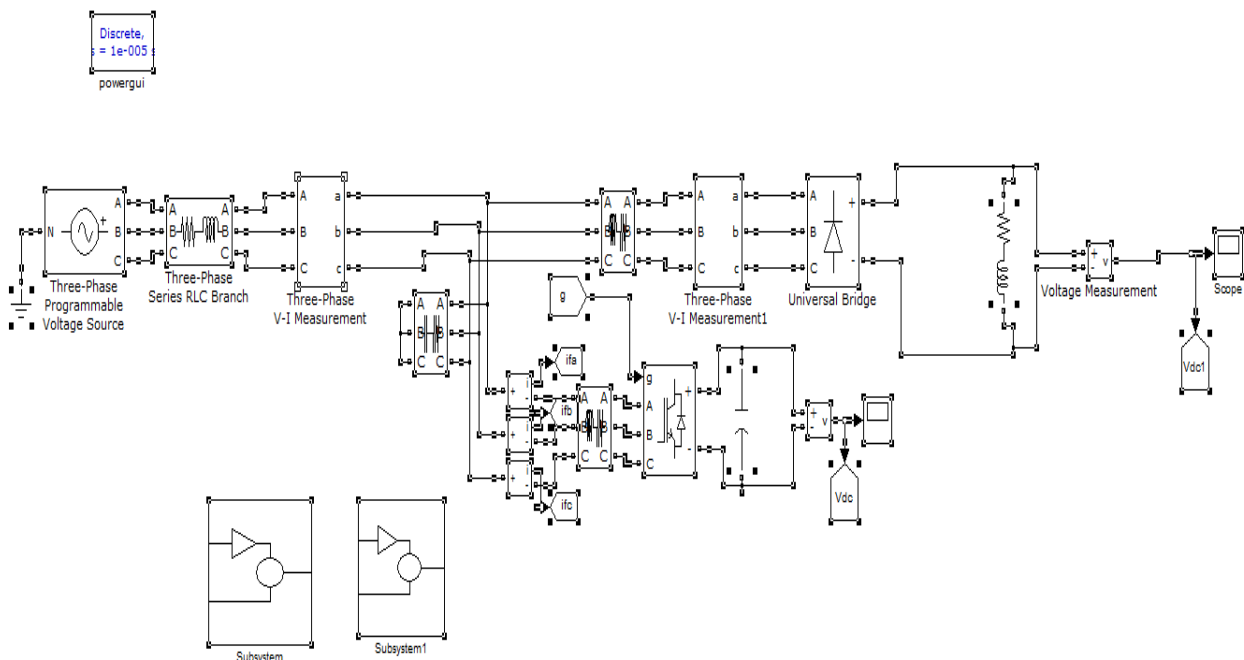

Figure 4. Main model of SRF based SAPF

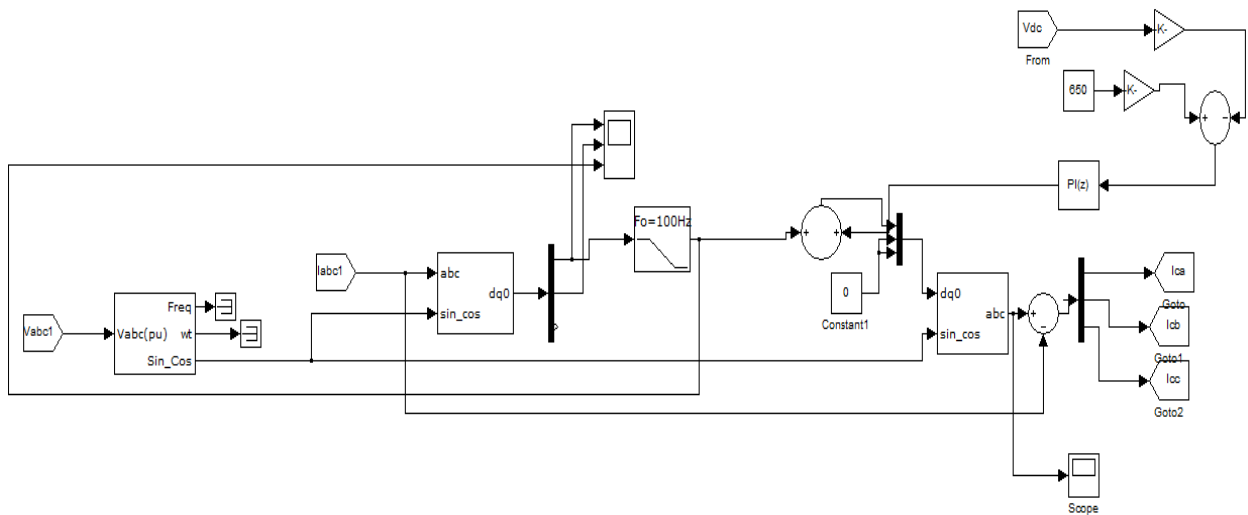

Figure5. Simulation Diagram of SRF based Current Control Strategy

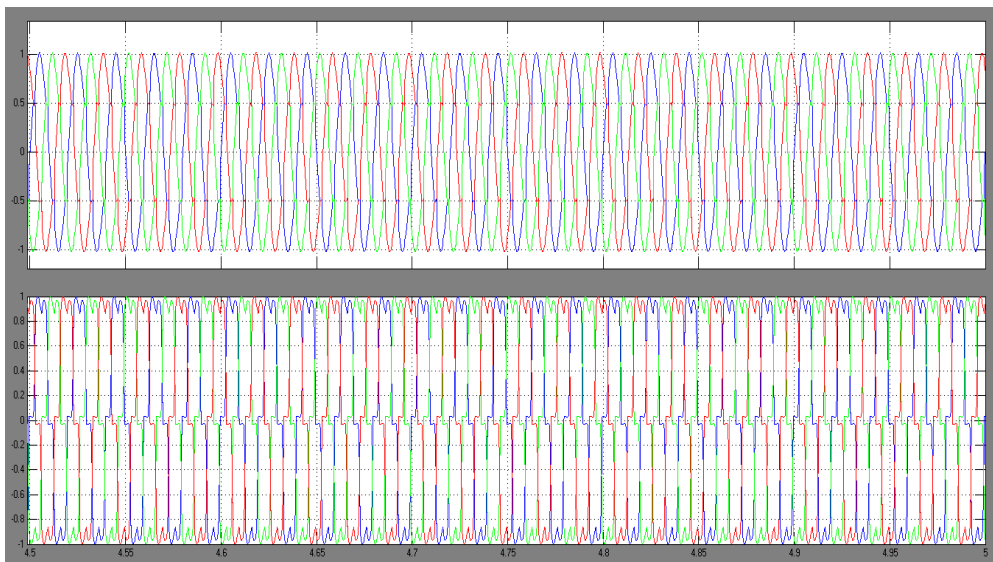

Figure 6. Source voltage and current profile without compensation

Figure6 shows the source and current profile without compensation .The current distortions are due to non-linearity produced by rectifier circuit. In Figure 7 the source side THD without compensation is 23.94%, which is very high and is the cause of the distortion in the current profile. Figure 8 shows the source and current profile with compensation. In Figure 9 the FFT analysis shows the source side THD is 3.77%. Hence the control strategy is working very fine.

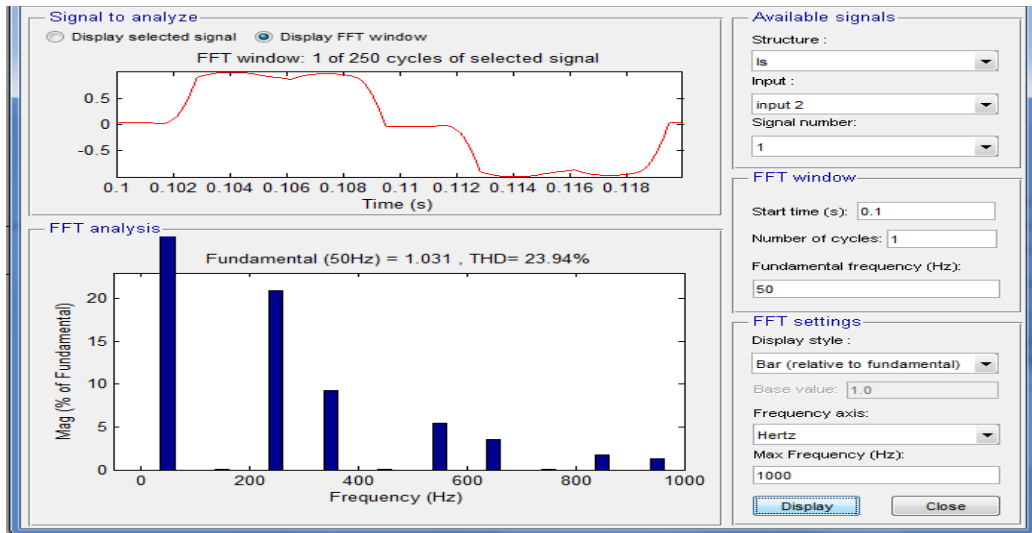

Figure 7. Source side THD without compensation

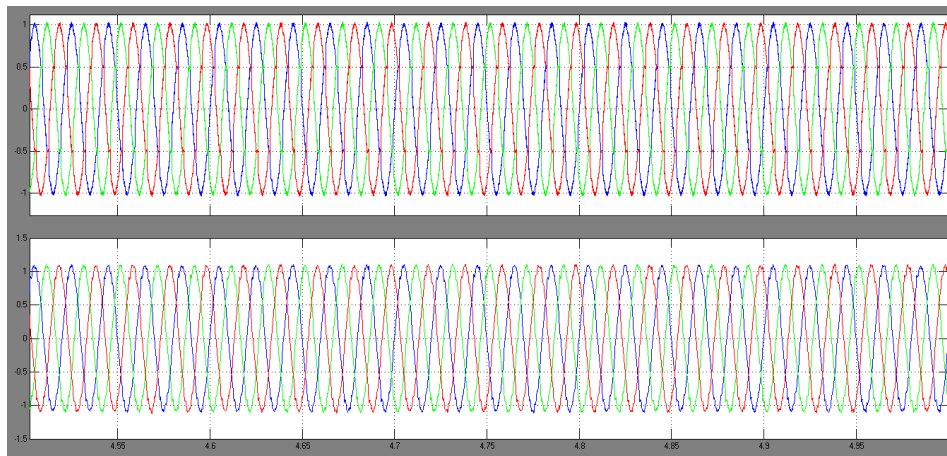

Figure 8. Source voltage and current profile with compensation

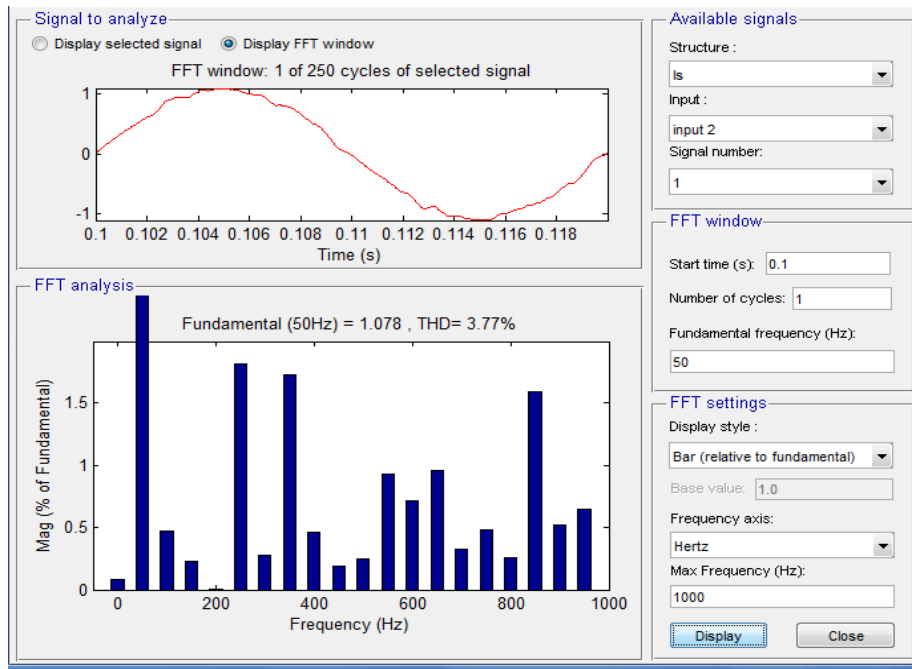

Figure 9. Source side THD with compensation

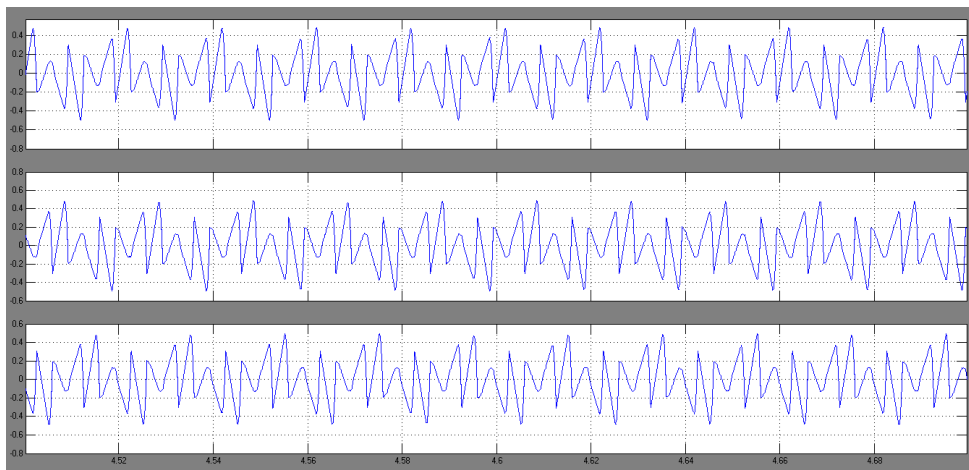

Figure 10. Three phase compensating currents (i_{cabc})

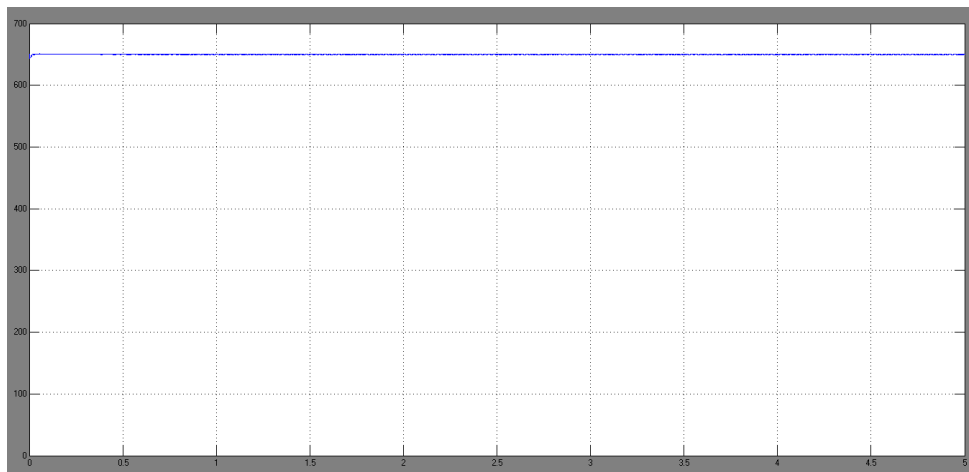

Figure 11. DC-link voltage profile

Figure 10 shows the generated compensating currents based on SRF theory. The generated currents were able to compensate source current distortion due to non-linearity satisfactorily. Figure 11 shows the DC link voltage. The PI controller is able to maintain the set voltage. It is required to keep the constant DC voltage for real power to flow during transient as well as steady state condition. Figure 12 shows the combined profile of source current, load current and compensating current to give the idea of, how the compensating currents are able to make the source current smoother or sinusoidal.

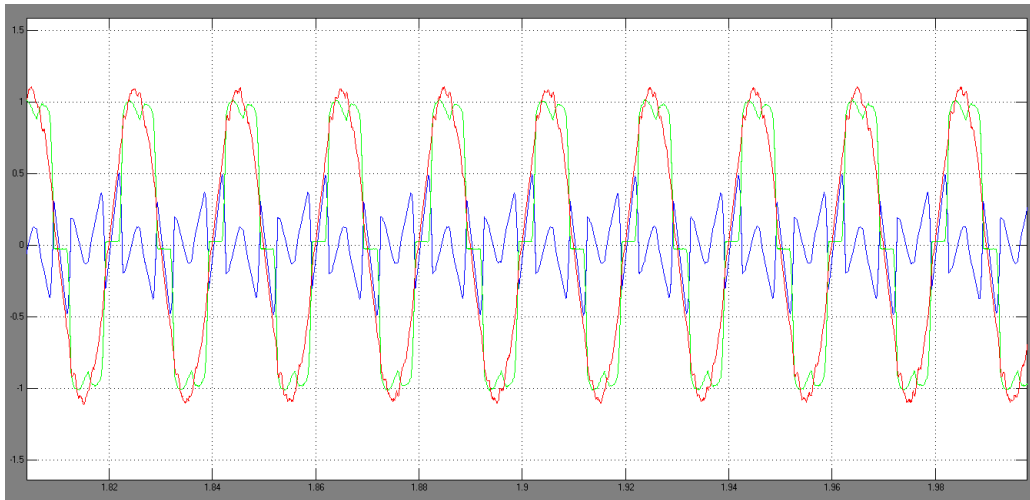

Figure 12. Combined profile of source current, load current and compensating current

IV. CONCLUSION

This paper describes the SRF theory based control strategy used in SAPF, which mainly compensates the current harmonics under non-linear conditions. Using the SRF based theory; the SAPF with PI controller was modeled. The performance of the SAPF was examined with simulation model. The result shows that current THD meets the recommended harmonic standards such as IEEE-519. Hence it is proved that by using the SAPF current harmonics can be mitigated.

REFERENCES

- [1] Hirofumi Akagi, Fellow, IEEE “Active Harmonic Filter” proceedings of the IEEE, vol.93, No. 12, December 2005.
- [2] Suntsrianthumrong and Hirofumi Akagi, Fellow, IEEE “A medium-voltage Transformer less AC/DC power conversion system consisting of a diode Rectifier and shunt hybrid filter”. IEEE Transactions on Industry Applications, Vol. 39, No. 3, May/June 2003.
- [3] Metin Kesler and Engin Ozdemir, Senior Member, IEEE “Synchronous-reference-Frame-Based control method for UPQC under unbalanced and distorted load conditions”. IEEE Transactions on Industrial Electronics, Vol. 58, No. 9, September 2011.
- [4] Digital Signal Controller TMS320F2812 (Texas Instruments) Technical reference manual.
- [6] Consalva J. Msigwa, Beda J. Kundy and Bakari M.M. Mwinyiwiwa, world Academy of science, Engineering and Technology, “Control Algorithm for shunt active Power Filter using Synchronous Reference Frame Theory”. World academy of Science, Engineering and Technology, Vol: 3 2009-10-20.
- [7] J. Rodriguez, senior member, IEEE, J. Espinoza, member, IEEE and P. Lezana “PWM Regenerative Rectifiers: State of the Art.
- [8] IEEE Recommended practices and requirement for harmonics control in Electrical power system IEEE Std. 519-1992,.