

**Power Quality Issues in Induction Furnace**Pradnya S. Narnaware¹, Dr. A.G. Thosar²¹M.E student, Electrical engineering department, Government College of engineering, Aurangabad, India-431001²Head of Electrical, Electrical engineering department, Government College of engineering, Aurangabad, India-431001

Abstract — *The Electric Induction Furnace is a type of melting furnace which uses electric currents to melt and refine the metal such as copper, lead aluminum, etc. Today, India ranks fifth in the world in EIF-based steel production and the production of steel by EIF is increasing adopted by Steel Industries. As the popularity and use of EIF in the industry increases, so does the power quality problem as a result of this progress. The EIF operation causes harmonic, inter-harmonics, voltage flickers, voltage instability and reactive power burden. The induction furnace significance heavy current within a view of distortion in the current waveform, this heavy distorted current effect distortion in the system voltage. Due to the insulation limitations at 11 KV lines, for modern Power Quality where the Analyzers has to capture the exact distorted voltage waveform. This induction heating furnace has problem such as low power factor, insufficient load, low efficiency and high system losses especially capacitor loss that are effected frequent damage to the parallel capacitor. Pure active filters were planned to mitigate passive filter disadvantages, while this is costly method. Sometimes rate power of active filter should be 80 percent of load power. Because both pure active filters and passive are not an ideal solution. The simulation model of the induction furnace was implemented in MATLAB software and output wave form analyzed.*

Keywords- Induction furnace Harmonics, Power Quality THD, Simulation

I. INTRODUCTION

The development of induction furnaces starts by Michael Faraday, who invented the principle of electromagnetic induction. Induction furnaces are used in an extensive range of production and developed services such as foundries and metallurgy plants. Induction furnaces are used basically because of quick clean melt of materials, easy maintenance and operations. Induction heating is mostly used in metal industry for melting, heating thin lump in continuous casting plant because of good heating, effectiveness, high manufacture rate and clean working environments. Induction heating equipment does not produce dust and noise in process of power quality problem in the electric power system. [1] [4] Electric furnaces are basically classified as Arc furnaces and Induction furnaces. The importance of induction melting indicates that a high voltage electrical source from a primary coil to induces a low voltage, to secondary high current in the metal and coil. Induction heating is just a method of transferring heat energy. Induction furnaces are perfect for melting and alloying a large variety of metals with minimum melt losses, few refining of the metal is potential. There are two most important types of induction furnace: Coreless and Core type. Induction heating mainly dependent on two physical phenomena: 1. Faraday-Lenz's law and 2. The Joule effect. With the increasing use of electric induction furnaces several power quality difficulties are introduced in the power system. In order to study the power quality issues related to induction furnace, there is a need to develop an accurate electric induction furnace model which can represent the furnace process with accuracy. Literature check reveals some of the methods for modelling and predicting the behaviour of electric induction furnace. Alexandre C. Moreira [3] study presents a detailed computer modelling of the induction furnace in PSIM software. To confirm the model, were used immediate currents and voltages previously measured at the terminals of an induction furnace to six-pulses of 15 KW. Furthermore, the use of these standards are suggested to analyze the possible impacts of the induction furnace, in the electrical power system. S. L. Gbadamos [9] developed a steel production plant from induction furnace. An induction furnace is an electrical furnace used for melting metals. It produces heat by an alternating current coil, a process is known as electromagnetic induction. The new generation of induction melting furnaces are concerned mainly with financial behaviour of producing steel. The problem with this kind of furnaces is that the formation of the significant harmonic distortion. Induction furnace loads are nonlinear, the harmonic currents generated by the loads determine the reason a voltage drop across source impedance with decrease in power quality distortions exceeds for over voltage excessive currents, overloading of power factor correction, increased error in energy meters, not working of protective gears for example inductive interference, relays and circuit breakers, and tripping of machines at smaller loads. Nihar P Bara [7] developed a general automatic optimization procedure joined to a finite element induction heating procedure simulation. The mathematical model and the numerical methods are obtainable along with grades validating the model. This paper presents the thermal induction heating mathematical model. The composite wall is consisting of mass, mica, cylinder and clay. The heat flux adding up is governed by the induction of the coil. The inductance of the coil is necessary for calculation of heat flux input. Viralkumar Solanki [4] performed simulation of induction furnace with actual induction furnace. Induction heating is commonly used in metal

industry for melting or heating thin piece in constant casting plant because of high-quality heating efficiency, high production rate and clean working environments. In this paper power, voltage, current, harmonic and THD measured of the actual arc furnace is compared with proposed matlab simulation

This paper presents a mathematical model of electric induction furnace is formulated form heat transfer .Section 2 deal with the basic of induction furnace , construction ,types and principle of electric induction furnace. Section 3 describes General power quality Issue .Section 4 describes the mathematical model of electric induction furnace is formulated form heat transfer .Section5 describes the induction furnace compensation by hybrid active filter. Section 6 describes the simulated electric induction furnace

II. INDUCTION FURNACE

Electric induction furnace is variety of melting furnace that use electric current to melt the metal .These furnaces are simple to mount, manage and preserve .These furnaces are smaller in heat size with a low cost investment and preferred by inferior capacity steel plants. In these furnaces, steel is produced by melting the charge material using the heat produced by electromagnetic field. The importance of induction melting indicates that a high voltage electrical source from a primary coil induces a low voltage, to secondary high current in the metal and coil. Induction heating is just a technique of transferring heat energy. Induction furnaces are perfect for melting and alloying a large variety of metals with minimum melt losses, a small number of refining of the metal is possible.

2.1 Construction of Induction Furnace

There are many different designs for the electric induction furnace but they are center around basic idea. The electrical coil is placed around or inside of crucible, which hold the metal to be melted frequently , this crucible is divided into two different parts. The lower section holds the melt in its purest form, the metal as the manufacturers wanted , while the higher section is used to take away the slag, the contaminants that increase to the surface of the melt. Crucibles may also be prepared with strong lids to decrease how much air has contact to the melting metal rest is poured out manufacture a purer melt.

2.2 Working principle of induction furnace

The power consumed by an induction furnace depends on the stages of the melting of the metal major problems on the electrical power distribution systems. The induction furnaces vary from the arc furnaces, in the generation of energy for heating of the metal which is melted In the induction furnace, the heat is created inside the crucible by circulate alternating current in the coil, which develops in the metal of an induced current of better intensity. The principle of the induction furnace is induction heating is based on two famous physical phenomena: electromagnetic induction and the Joule effect [3].

The induction furnace is a nonlinear load. A large nonlinear load such induction furnace draws heavy non-sinusoidal current further the fundamental current component there is no sinusoidal current contains undesired frequency components known as harmonics.[3] A converter has mixture of rectifier and an inverter. Converters are highly used in industry. Frequently these converter are used as induction heating furnaces have a three phase rectifier and a single phase inverter. In these converters load of induction heating furnace can be controlled in the form of parallel and series with a capacitor bank. The rated output power and frequency of induction furnace are 70kW and 2KHz and the rated input voltage and frequency are 415V/AC and 50Hz.The capacitance of capacitor bank affects the by and large operating factor of induction heater such as resonance frequency Q factor efficiency. In this paper power, voltage, current, harmonic and Total Harmonic Distortion (THD).Most important of actual induction furnace is compared with proposed Matlab simulation which is offered in this paper. [4]

2.3 TYPES OF INDUCTION FURNACES

There are two main types of induction furnace: coreless and core type

2.3.1 Coreless Induction Furnaces

The coreless induction furnace is the coil consists of a vacant segment of heavy responsibility, high conductivity copper tubing which is cut into a helical coil. To protect it from overheating, the coil is water-cooled, with cooling tower. The coreless induction furnace is usually used to melt all grades of steels and irons in addition to various non-ferrous alloys. The furnace is model for remolding and alloying because of the high degree of organize over temperature and chemistry with the induction current provides good flow of the melt.

Coreless induction furnace



Figure 2.3.1 Coreless Induction Furnaces

2.3.2 Channel Furnaces

The core induction furnace consists of a unmanageable smooth steel shell which contains the melt metal .The heat generated inside the loop causes the metal to circulate into the main well of the furnace. Core induction furnaces are commonly used for small melting point alloys which as a holding and superheating unit for higher melting point alloys such as cast iron

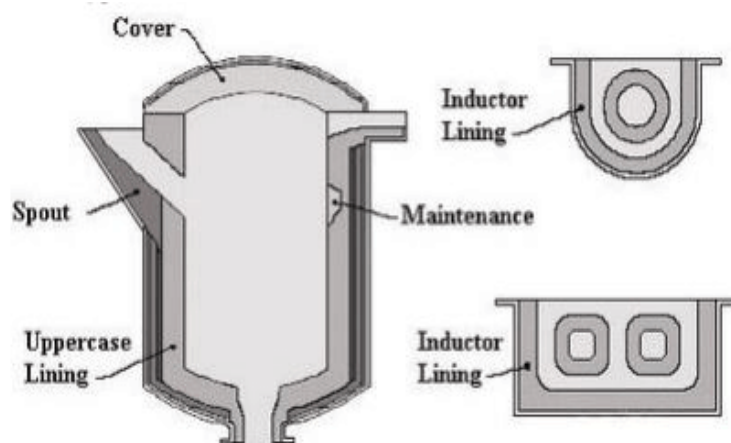

Figure 2.3.2 Channel Furnaces

2.3.3 Pressure Pour Furnace

A pressure pour is a channel furnace, that is conserved that the metal can be moved out of the furnace technique of pressurizing the chamber

2.3.4 Safety Implications

Accident research reports indicate that most metal works accidents happen due to one of the next reasons

- 1) The preamble of wet or moist metal into the melt, causing a molten metal explosion
- 2) Lack of hand skill during temperature taking, variety of alloying compounds
- 3) Reducing large piece of allege material into a molten bath
- 4) Breakdown to place behind safety lines, causing a drumming situation
- 5) Offensive awareness to charging causing a bridging condition
- 6) Lack of hand training [2]

2.4 Basic Block Diagram of Induction Furnace

In this section, A converter has a rectifier and an inverter. These converters are used in the induction heating furnaces has a three phase rectifier and a single phase inverter. In these converters, load of induction heating furnace can be controlled in the form of parallel and series with capacitor bank. If changing current of switches of inverter are varied by changing current load naturally.[4]

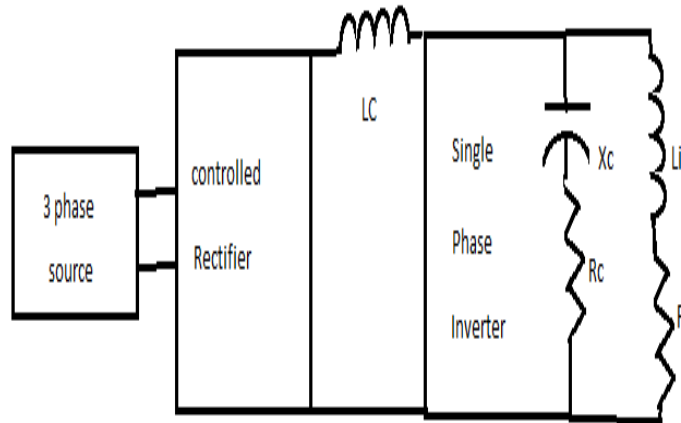

Figure 2.4 Block diagram of an induction heating furnace

These inverters usually call load commutation inverter. In this paper Figure 1 represents block diagram of a parallel resonant induction heating furnace is 70Kw. This induction heating furnace has issues such as low power factor, insufficient and non adapted power with load, low efficiency and high system losses particularly capacitor loss caused by frequent damage to the parallel capacitor damaged. For these reasons, we optimized Power supply of induction heating furnace is a three-phase supply with voltage amplitude 415V and frequency of 50Hz. Source voltages are rectifying in an uncontrolled rectifier, converted into DC voltage and concern into a single phase inverter Output voltage, amplitude and frequency are 600V and 2000Hz, correspondingly

2.5 Rating of induction furnace

The rated output power and operating frequency of induction furnace are 75KW and 2000Hz and the rated input voltage and furnace current consumptions are 415V and 120Amp. IGBT and Thyristor used in inverter and rectifier respectively.[4]

Power	75 kW
Voltage	415V
Furnace consume current	120 Amp
Admittance	7 μ Mho
Operating frequency	2000Hz
Iron melting capacity	120 Kg
Maximum temperature	1650 ^o C
Inverter	IGBT
Rectifier	Thyristor bridge

Table 2.5 Design Values for Proposed Matlab Model

2.6 USE OF INDUCTION FURNACE

India is the first country using Induction Melting Furnaces for production of mild steel. The bulk of structural quality mild steel for long products is manufactured by Induction Melting Furnaces. During 2001-2002 period over 4.3 million tons of steel were produced by Induction Furnaces, which has reached a level of 4.7 MT in 2002-03. The EAF units have also installed Induction 45 Comprehensive Industry Document on Electric Arc & Induction Furnaces melting furnaces. There are several reasons for the popularity of Induction Melting Furnaces for making steel. They consume less power comparing EAF's. Expenditure on electrode is nil. They use lesser quantity of refractory. Initial investment is less on plant and equipment. Thus, there are economic advantages in making steel through Induction Furnaces route. The environmental pollution in case of EAF is much more than Induction furnaces. The only snag of steel production through induction furnace route is of capacity limitation. [5]

Development course	2005-06	2010-11 (P)
Induction furnace (IF)	29%	32%
Basic Oxygen Furnace	53%	44%
Electric Arc Furnace (EAF)	18%	24%
Total	100%	100%

Table 2.6.1 Indian rough steel production (Percentage share)

The following charts represent the state wise and region wise distribution of IFs.

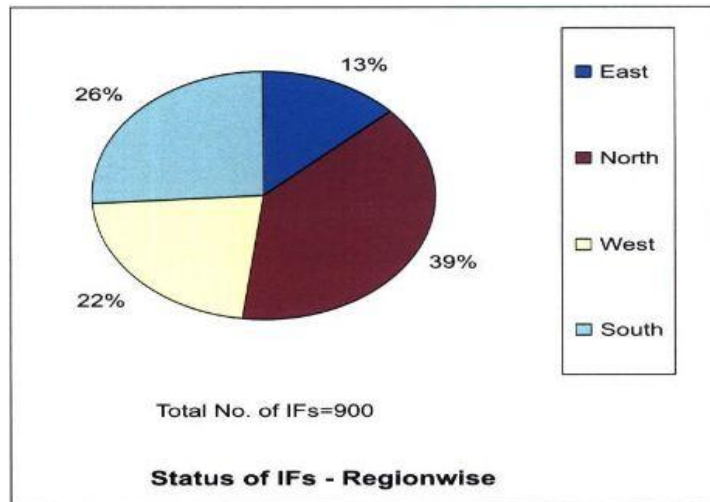

Fig. 2.6.2 Regionwise Status of IFS

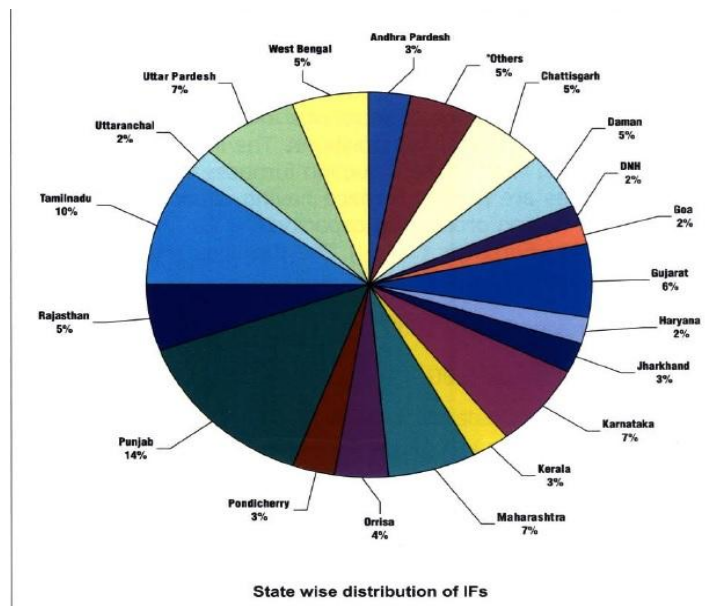

Fig. 2.6.2 Statewise Status of IFS

III. POWER QUALITY

Power Quality may be defined as a terms of voltages and a scheme plan so that the user of electric power can develop electric energy from the sharing system successfully, without interference on interruption. The term Power Quality is defined in the Institute of Electrical and Electronics Engineers Standard Terms as "the concept of powering and grounding electronic equipment in a way that is appropriate to the process of that equipment and well-matched with the premise wiring system and other connected equipment." Utilities may want to define power quality as reliability. PQ is an important issue for electricity consumers at all level of practice, particularly industries and the services region. We widely use responsive power electronic equipment and non-linear loads in industry for commercial and domestic applications. In such an surroundings harms like power surges, sags, poor voltage and frequency regulation, harmonics, switching transients, electrical sound and the Electro-Magnetic Interference effect are often encountered

This leads to harmed resources-intensive appliances, safety concerns, loss of consistency and above all a hold close economic loss.

3.1. Standards related to Voltage Sag and Reliability .

The distribution voltage quality standard i.e. IEEE Standard gives the suggested indices and procedures for characterizing voltage sag performance and comparing presentation across dissimilar Systems .A new IEC Standard "Environment —Voltage Dips and Short Interruptions" has recently introduced. This standards warrants considerable conversation within the IEEE to avoid conflicting methods of characterizing system performance in different parts of the world [10]

3.2. Standards related to Flicker .

Developments in voltage flicker standards display how the industry can effectively organize IEEE and IEC activities. IEC Standard defines the procedure and check requirements for characterizing flicker. The IEEE flicker team working on Standard is set to adopt the IEC standard as its own [10].

3.3. Standards related to Custom Power .

IEEE Standard is at currently building an application guide for custom power technologies to offer improved power quality on the distribution system. This is an important area for many utilities that may want to improve enhanced power quality services

3.4. Standards for Steady condition Voltage Regulation and Unbalance

There is no such thing as steady state on the power system. Loads are frequently changing and the power system is continually adjusting to these changes. All of these changes and modification ends up with voltage variations that are referred to as long duration voltage variations. These can be under voltages or overvoltage, depending on the specific circuit conditions. Features of the steady state voltage are best expressed with long duration profiles and statistics. Important features include the voltage magnitude and unbalance. IEEE suggests Practice for Monitoring Power Quality, lengthy duration variations are considered when the limits are exceeded for greater than single minute. Harmonic distortion is also the feature of the steady state voltage but this feature is treated separately because it does not involve variations in the fundamental frequency component of the voltage [10].

3.5. Standards for Harmonics

Harmonic distortion of the current and voltage results from the operation of non-linear loads and devices on the power system. The non-linear loads that forms harmonics can often be represented harmonics's current sources. The system voltage appears hard to individual loads and the loads draw distorted current waveforms.

3.6. Standards for Voltage Sags and Interruptions

Voltage sags is categorised into short duration voltage variations. According to IEEE and IEC definitions, it is then consist variations in the fundamental frequency voltage that last less than one minute. These variations are characterized by plotting r.m.s voltage Vs time but it is often adequate to describe them by a voltage magnitude and the duration that the voltage is outside of specified range. It is not mandatory to have detailed waveform plots since the r.m.s voltage magnitude is of primary concern. The voltage variations can be a loss of voltage (interruption) ,momentary low voltage (voltage sag) high voltage (voltage swell) .

IV. MATHEMATICAL ANALYSIS

Principal Equation – The heat transfer study of the induction furnace is governed by the thermal diffusion equation in cylindrical form and it is given by equation (1)

$$\frac{1}{R} \frac{\partial}{\partial R} (KR \frac{\partial T}{\partial R}) = C_s P \frac{\partial T}{\partial t} \quad (1)$$

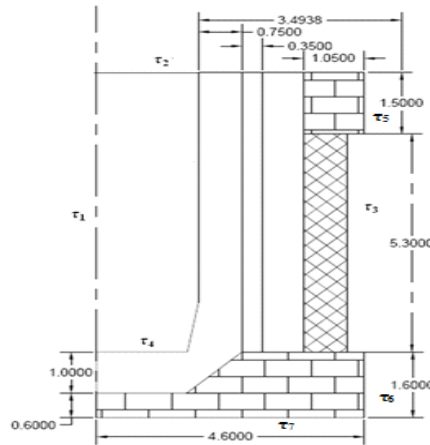

Figure.4.1 Domain of the Induction furnace

Where C is the specific heat capacity and density of the wall material, R, θ and Z are cylindrical coordinates.

$$\frac{1}{R} \frac{\partial}{\partial R} (KR \frac{\partial T}{\partial R}) = C_s P \frac{\partial T}{\partial t} \quad (2)$$

On $\tau_1 \tau_2 \tau_3 \tau_4 \tau_5 \tau_6 \tau_7$

$$\frac{1}{R} \frac{\partial}{\partial R} (KR \frac{\partial T}{\partial R}) = 0 \quad (3)$$

On τ_3

$$\frac{1}{R} \frac{\partial}{\partial R} (KR \frac{\partial T}{\partial R}) = q \omega \quad (4)$$

On τ_4

$$\frac{1}{R} \frac{\partial}{\partial R} (KR \frac{\partial T}{\partial R}) = h(T - T_0) \quad (5)$$

$$q_w = (1/2) I^2 L_t / A \quad (6)$$

$$L = \mu_0 \mu_r N^2 A / I \quad (7)$$

Fig.4.1 shows the area considered for the analysis and in this work, the area is symmetric about the axis hence the axis symmetric condition has been taken for the purpose of the analysis and to lower the complexity in the calculation. The composite wall is consists of mass, mica, sintering cylinder and ceramic wall. The boundary conditions considered for the calculation is shown above. The boundary condition is applied along τ_1 and axis symmetric condition is applied along the axis and is considered as insulated i.e. There is no heat exchange across the τ_1 , τ_2 , τ_5 , τ_6 and τ_7 boundaries. Around the boundaries τ_3 , τ_4 the coil is rounded and hence the heat flux is entering through it. The heat flux condition is described in the boundary condition along those boundaries 9-12. The calculation of heat flux is governed by the

induction of the coil. The inductance of the coil is necessary in the calculation of the heat flux input. The specification of the furnace used in the industries has been utilised for calculation for the study . The coil is having 15 numbers of turns around the furnace. The cross section and permeability of the coil determines the inductance. The quantity of the heat flux enters through the composite wall is governed by the different combinations of the composite wall thickness . The width of the furnace is about 600 mm and the calculations have shown that the 15000 W/m² amount of heat flux acts on the furnace.[7]

V. HARMONIC MITIGATION BY HYBRID ACTIVE FILTER

Input current at induction furnace supplied with voltage source type inverter has worse THD than current source type. For convenience, a diode rectifier with resistive – capacitive load at output that has characteristic like voltage source type inverter was simulated. An inductor was put in rectifier input. This inductor improve stability margin of system and reduce THD current [8]. Two hybrid active filter with the process presented above was simulated in MATLAB. In this simulation two single tuned passive filter were used shows simulation results without active filter. THD is less than 5% shows simulation results when active filter is along passive filter. In both simulated cases dc capacitor voltage was 40 volts and only active filter was displaced.

5.1 Passive filter

The normal filtering approach for harmonic producing loads is to place at least one series-tuned resonant shunt near the source of the harmonics. If only one filter is used, it is usually tuned at the lowest characteristic harmonic. The furnace is capable of exciting this resonance when operating in its low frequency range. This will very likely result in filter failure. The capacitor bears no relation to the size of the load, but rather to the short circuit impedance of the system. Thus, the capacitor could be very large relative to plant load. Very large currents were injected when the furnace frequency slipped too low. The drawbacks of this approach are cost of the capacitors and very poor voltage regulation. Also, the utility may not be able to accommodate the excess reactive power.

5.2 Active Filtering

Active filtering refers to any number of schemes for using series- and shunt-connected electronic power converters to compensate for the frequencies produced by the furnace. A series active filter built directly into the furnace power supply [8]

VI. SIMULATION OF ELECTRIC INDUCTION FURNACE

6.1. Source

Induction heating furnace cause is virtual by three- phase sources with sequence a, b, c. Every source has 120⁰ maximum of amplitude of 415V and frequency of 50Hz that has 120⁰ phase different between phases. A pure inductor 80 μH is linked to each phase. These inductors demonstrate source reactance and reactance require to protect the rectifier Thyristor from high di/dt. Also, this reactance is of snubber's circuit. Simulated rectifier has three-leg and six . Thyristors example from T1 to T6.[4]

6.2. Block Diagram of Simulation

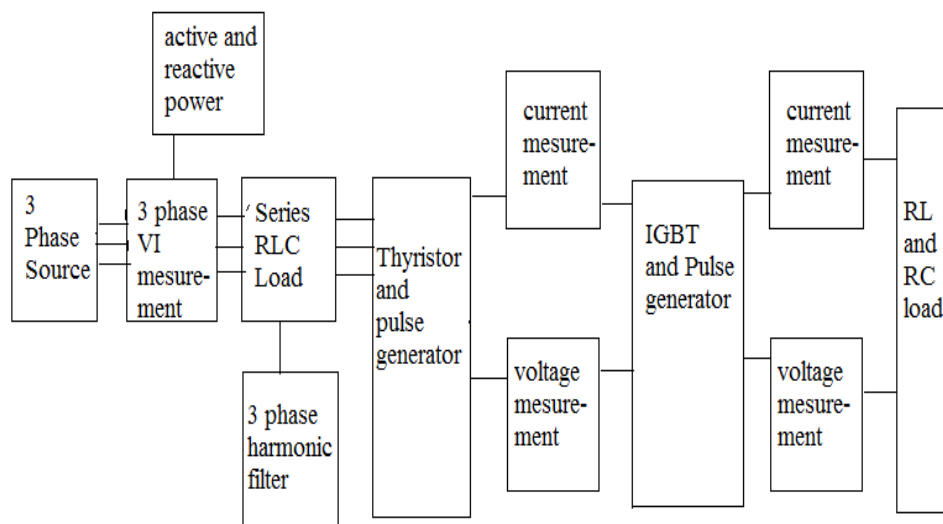

Fig. 6.2 Block diagram of simulating system

6.3. Simulation of Electric Induction Furnace Model

For involving rectifier and inverter to each other, an inductor of 20mH is used. For converting DC to AC a two leg inverter is used. Each inverter leg has two IGBT switches which is anti-parallel diode are linked.

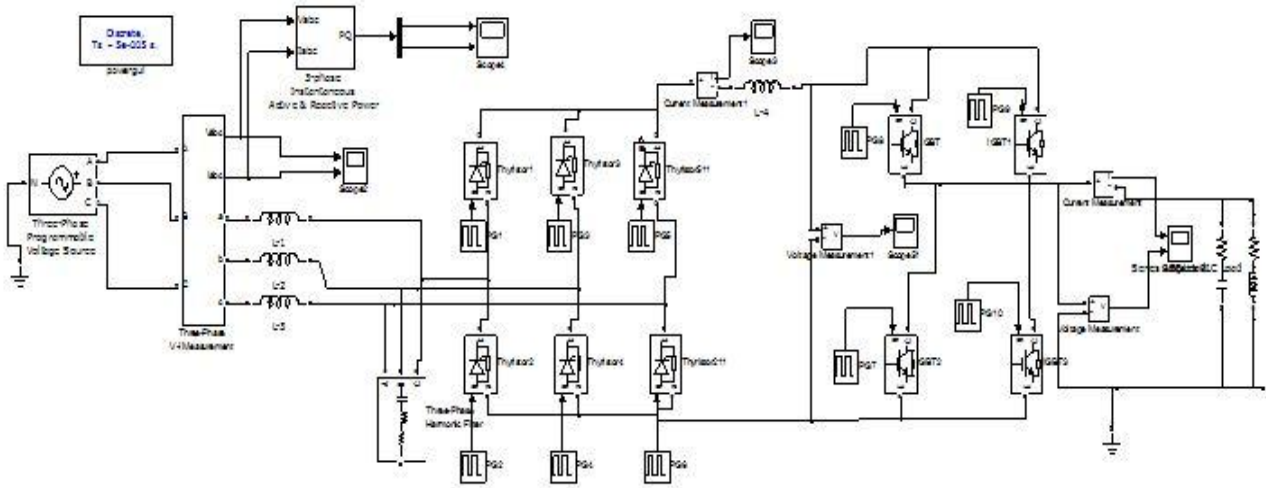

Fig. 6.3 simulation of system

According to unipolar PWM method are used. For preparing appropriate pulses and applying into the inverter IGBT switches, a triangular wave shape by frequency of 1500 Hz that has 180 phase difference to each other.

VII. RESULTS AND DISCUSSION

1. Basically induction furnace output current is quasi square wave (sinusoidal) type, but at here simulation production current is sinusoidal because of calculation of simple passive filter.
2. Initially starting of induction furnace power factor is small, and operates at full load lies between 0.8 to 0.9, so development of Power factor add capacitor bank
3. Matlab simulation, Current harmonics analysis THD is less as compare to the harmonics data of practical data.

The reproduction of Induction furnace power mainly two type, one is power control by rectifier firing angle and second one is power control by inverter, we are rising rectifier firing angle easily and accomplished the simulation by output inverter voltage and current, system stability , rectifier firing angle increases pending system becomes unsteady at the rectifier firing angle of just about 120°. Simulation think as small section melting industry so that have not reasonable filtering apparatus, but taking away of harmonics they have to use only capacitor bank. This simulation run in matlab simulink

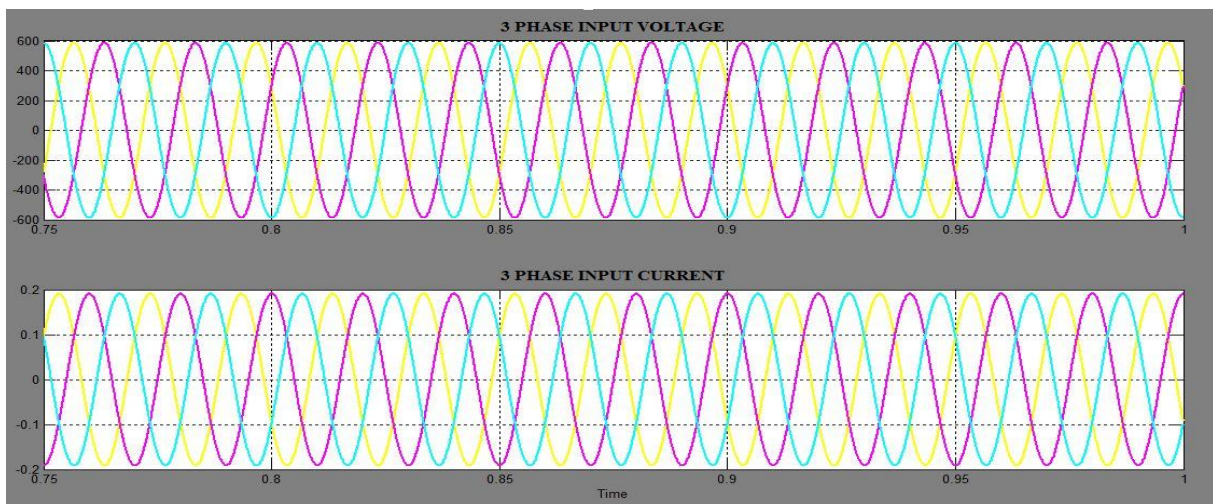

Fig. 7.1 Phase input voltage and current

Fig. 3.1 display's the input current and voltage. Then bridge rectifier is connected to the IGBT inverter. The pulses to the gate of IGBT's are provided from pulse generator.

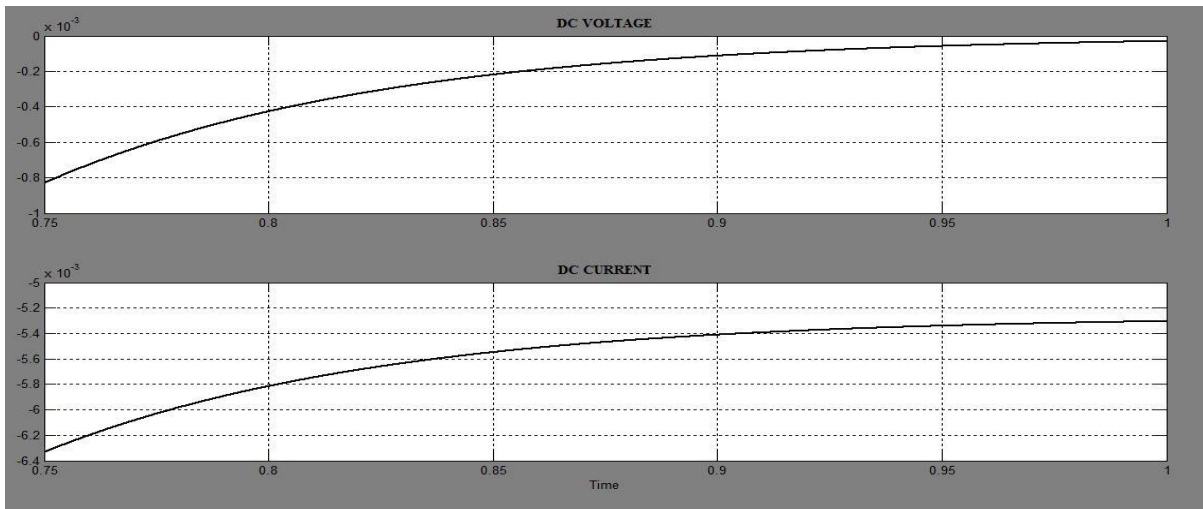

Fig. 7.2 Output current and voltage

Fig. 7.2 display's the DC link voltage and current and Fig. 7.3 display's output of thristier based rectifier also in fig. 7.4 active and reactive power of input side shown

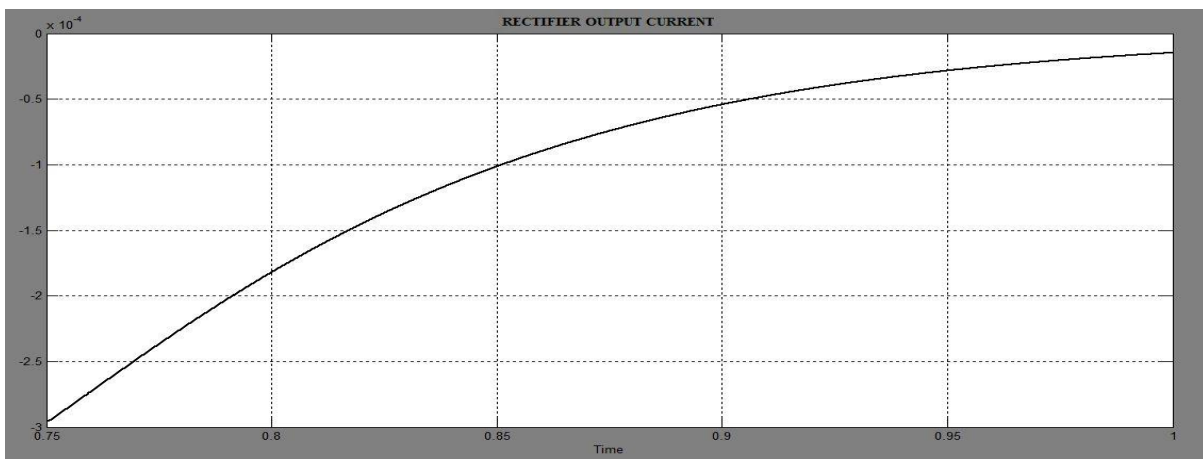

Fig. 7.3 Output of Rectifier

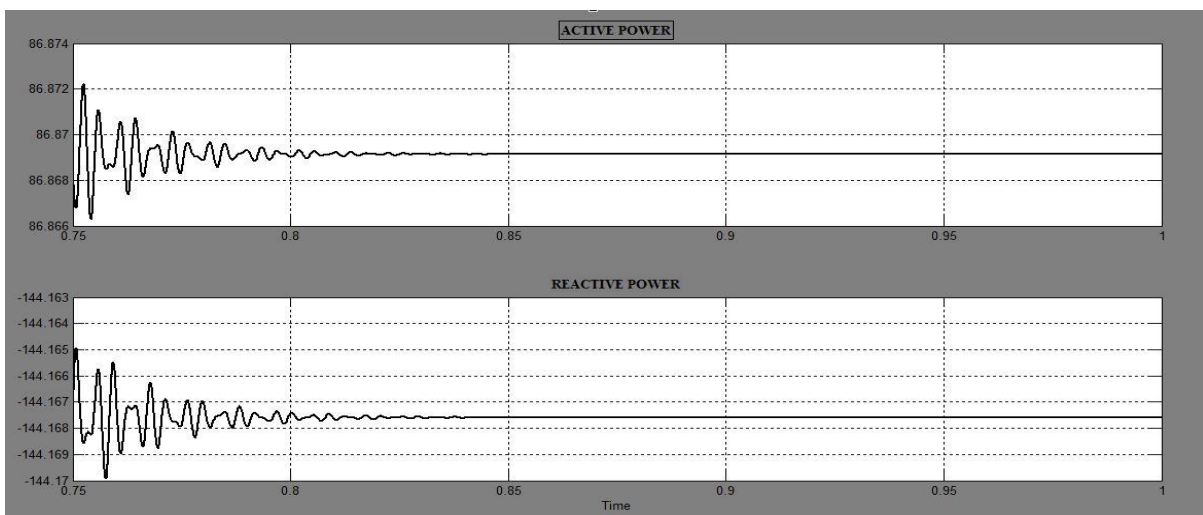

Fig. 7.3 Active and Reactive Power

VIII. CONCLUSION

In this paper gives review by analyzing power quality problems issues related international standards and the solution Harmonics are tightly coupled that one can place limitations on the current harmonics produced by nonlinear loads using the widely conventional idea of power factor, only if that true power factor is used relatively than displacement power factor.

When the full load is connected to the scheme and APFC linked then its power factor is close to the contract if not then power factor is reduce. Matlab simulation, Current and voltage harmonics analysis THD is less as compare to the harmonics data of actual practical data

REFERENCES

- [1] M. Salehifar, A. Shoulaie “Induction Furnace Compensation Using a Hybrid Active Filter”
- [2] Vivek R. Gandhewar, Satish V. Bansod, Atul B. Borade, “Induction Furnace - A Review”, International Journal of Engineering and Technology, Vol.3, pp.277-284,201
- [3] Alexandre C. Moreira and Luiz C.P. da Silva, Helmo K. Morales Paredes “Electrical Modelling and Power Quality Analysis of Three-Phase Induction Furnace”
- [4] Viralkumar Solanki, Sanjay R Joshi, Jiten Chavada, Kashyap Mokariya, “Simulation of Induction Furnace and Comparison with Actual Induction Furnace” IJRTE Vol.2 Issue-4, September 2013
- [5] “Comprehensive Industry Document on Electric Arc a Induction Furnaces” COINDS/80/2009-10
- [6] A. de Almeida, L. Moreira. J. Delgado “Power Quality Problems and New Solutions” Vol. 1, No.1, April 2003.
- [7] Nihar P Bara “Finite Element Analysis of Induction Furnace for Optimum Heat Transfer” International Journal of Innovative Research in Science, Engineering and Technology Vol. 2, Issue 5, May 2013
- [8] R C. Dugan, “Impact of Induction Furnace Interharmonics on Distribution System,” IEEE Transactions on Industry Applications, vol. IA-16, no. 6, pp. 813-818, Nov./Dec. 1980.
- [9] S.L.Gbadamosi¹* A.O.Melodi² “Harmonic distortion from induction furnace loads in a steel production plant” Vol.3, No.10, 2013
- [10] Mark McGranaghan “POWER QUALITY STANDARDS”