

**Controlling of Grid Connected Photovoltaic System***(grid synchronization to pv system)*Dimple B Chaudhary<sup>1</sup>, Amitkumar B Panchal<sup>2</sup><sup>1</sup>Electrical Engineering department, Parul Institute of Engineering and Technology<sup>2</sup>Electrical Engineering department, Parul Institute of Engineering and Technology

---

**Abstract** —The sale of electric energy generated by photovoltaic plants has attracted much attention in recent years. The installation of PV plants aims to obtain the maximum benefit of captured solar energy. The different techniques of modelling and control of grid connected photovoltaic system with objective to help intensive penetration of photovoltaic (PV) production into the grid have been proposed so far in different papers. The current methodologies for planning the design of the different components of a PV plant are not completely efficient. Therefore lot of research work is required for the grid connected PV system, the MPP tracking algorithm, the synchronization of the inverter and the connection to the grid. This project focuses on modeling of PV array, boost converter, VSI inverter and filter using MATLAB/Simulink. Controlling techniques are used like P & O algorithm for maximum power point tracking, DQO, phase locking loop and PI controller for inverter controlling and to synchronize the P source to grid.

---

**Keywords-** Photovoltaic array, dc-dc boost converter, dc-ac inverter, maximum power point tracking, dqo transformation, phase locking loop control.

**I. INTRODUCTION**

Photovoltaic system has so many advantages due to which its use is increasing day by day. Conventional sources like coal, petrol and many more will not be available after some years so we need to find alternative sources for that and this alternative sources are renewable energy sources like solar energy, wind energy, tidal energy, biogas etc. these non-conventional sources of energy have become very popular due to their benefits. We are dealing with solar energy which has so many advantages like it is pollution free, absence of fuel, energy has no cost, high reliability, simplicity of allocation, low maintenance, lack of noise and wear because of the absence of moving parts and the most important advantage of using the solar energy source is the decreasing in the cost of pv panels and the growing efficiency of solar pv cell.

With the growing non-conventional energy sources and the distribution system needs many latest technologies for operating and maintaining the electric grid so as to match the grid and also to improve the quality and its reliability. Photovoltaic module is the unit of conversion of power of the solar photovoltaic system. Output from the solar photovoltaic source system depends upon the irradiance and the temperature of cell, according to this the output voltage varies as irradiance and temperature keeps on changing with time. The I-V and P-V characteristics are non-linear, so it makes necessary to model for the maximum power point tracking for the pv system applications. From past few years the model of pv array has been made in the matlab/Simulink. The model of photovoltaic module/array describes the characteristics affected by the irradiance and cell temperature and also the load side voltage. The equivalent circuit of pv array are implemented in matlab/simulink is platform for the power electronics. It is used for many power electronics applications.

The capacity of solar photovoltaic systems are being increasing day by day are bringing many challenges to the electric grid.

For the electrical supply the stability of the grid as well as the security of the supply are very much important. Control technologies as well protection mechanism should be employed in the generating and distribution systems to minimize outages. The non-conventional energy sources has become most significant and contribute to the utility grid.

**II. Modelling of PV System**

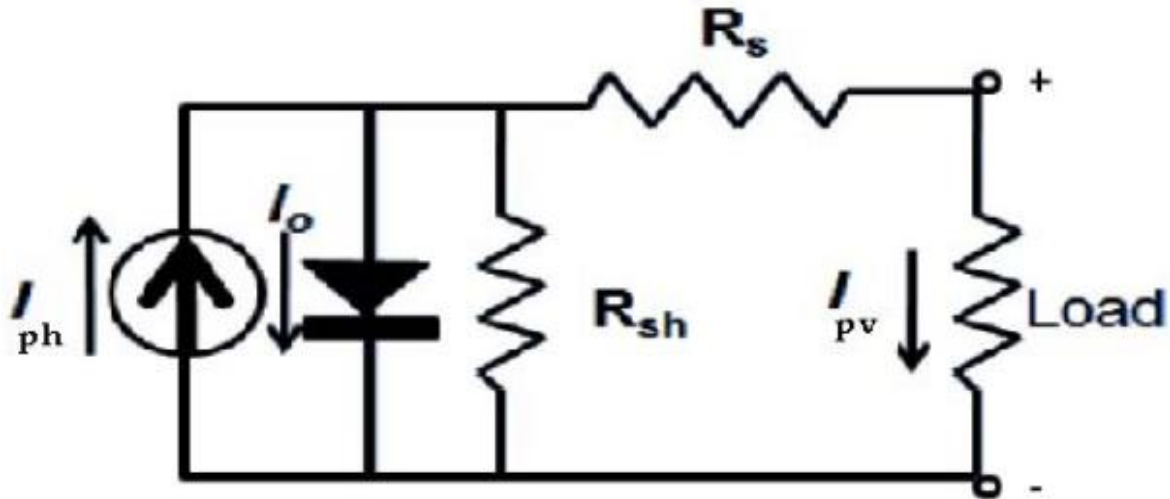

Fig.1 pv cell model

PV systems are manufactured to withstand the most rugged conditions. Modules are designed to endure extreme temperatures, at any elevation, in high winds, and with any degree of moisture or salt in the atmosphere. Systems can be designed with storage capabilities to provide consistent, high-quality power even when the sunlight is not proper.

As we can show in fig 2, that PV array is getting irradiation 1000w/m<sup>2</sup> and 25 degree temperature. output of PV array is connected to boost converter to step up the voltage and to get constant DC output.

In this model, we are using pv array from Simulink library which is Trina TSM305PA14.

### III. DC-DC Boost Converter with MPPT CONTROL

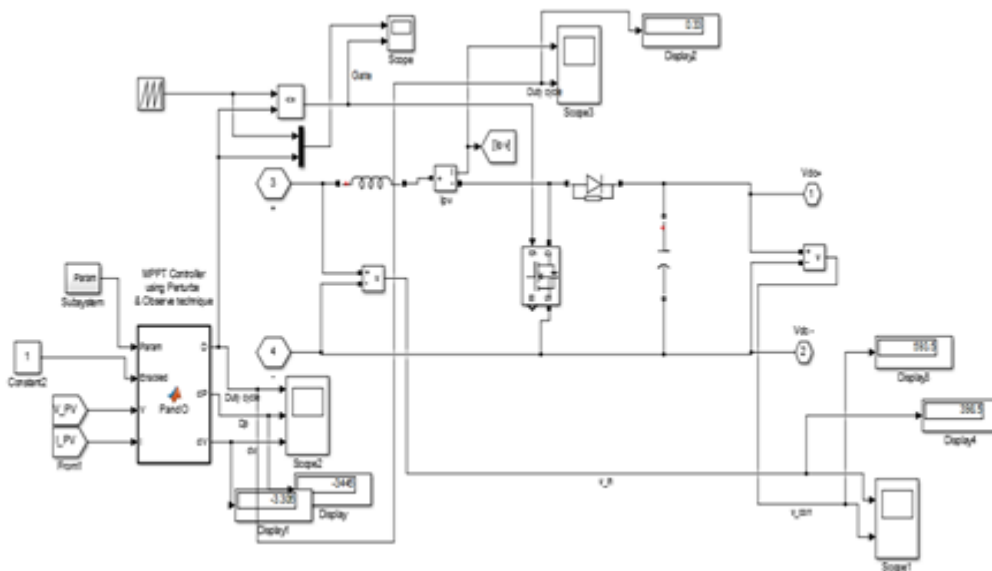

Fig.2 DC-DC Boost Converter with MPPT Controlling

Boost converter is a DC-DC power converter that steps up voltage (while stepping down current) from its input to its output. It is a class of switched-mode power supply containing at two semiconductors capacitor and inductors which smooths and filters output taken from inverter. Boost converter is placed between inverter and PV array. Here, we given duty cycle from MPPT control to switch used in boost converter.

There are so many techniques are used for MPPT control which gives the maximum output from PV array. We have used Perturb & Observation MPPT technique for boost converter. Because it is easily implemented and less complicated

from other techniques. We used duty cycle generated from this MPPT technique given to DC-DC boost converter and it converts to AC at inverter next to it.

Mppt i.e. Maximum power point tracking, it is a technique which is commonly used in the solar photovoltaic systems and also with wind turbines, as to maximize the power extraction under all conditions. The principle is applied generally to source side with variable power.

The purpose of the maximum power point tracking system is to sample out the output of photovoltaic cells and apply proper resistance as to obtain the maximum power for all the weather conditions. MPPT control is employed in dc-dc boost converter hat provides voltage or current conversion, filtering and the regulation to drive many loads.

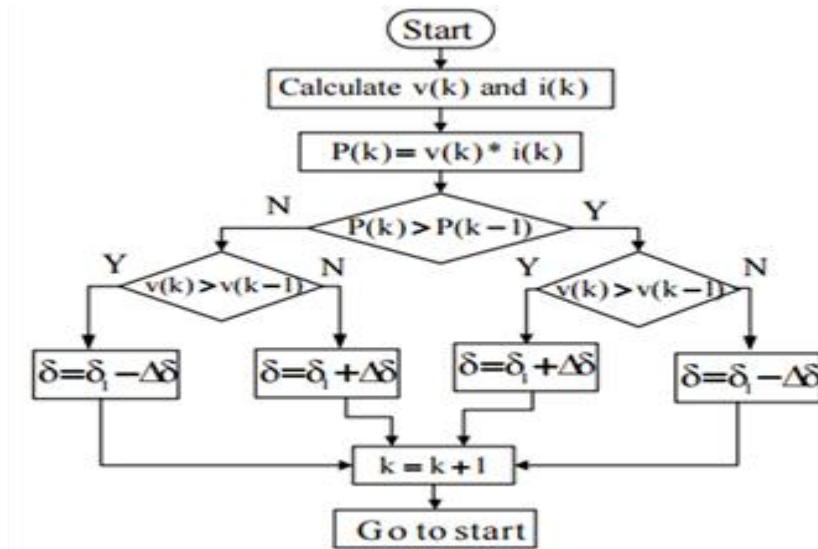

Fig.3 Perturb and Observe algorithm

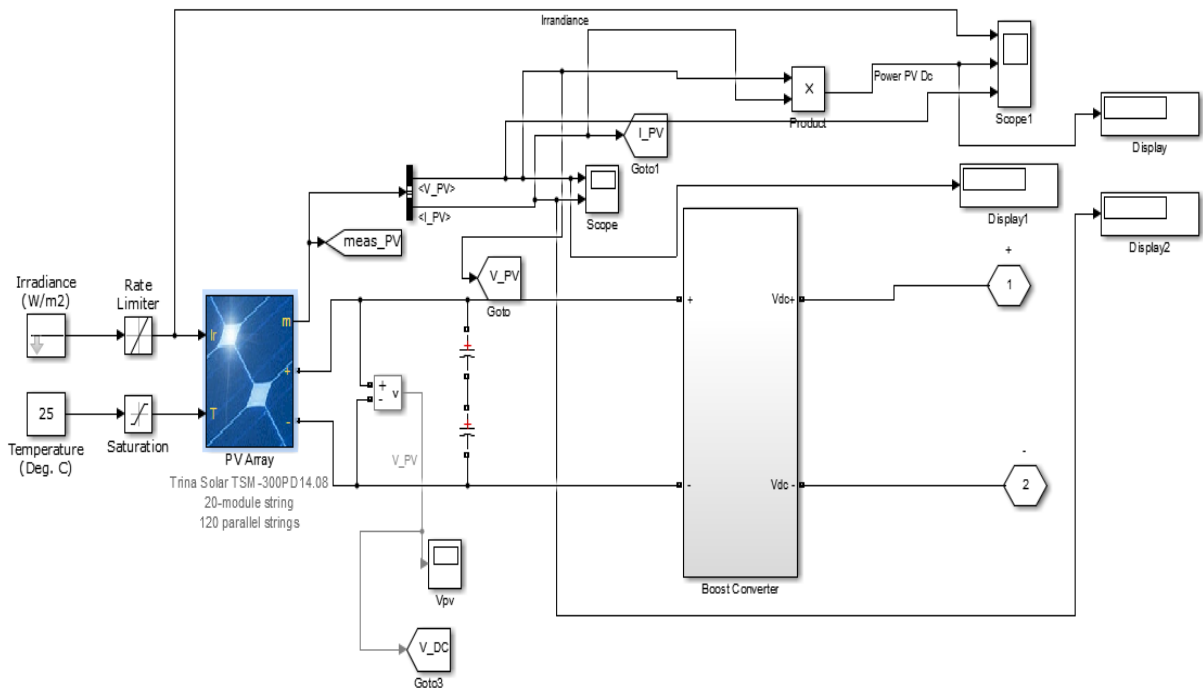

Fig.4 PV array connected to boost converter

#### IV. DC-AC Inverter

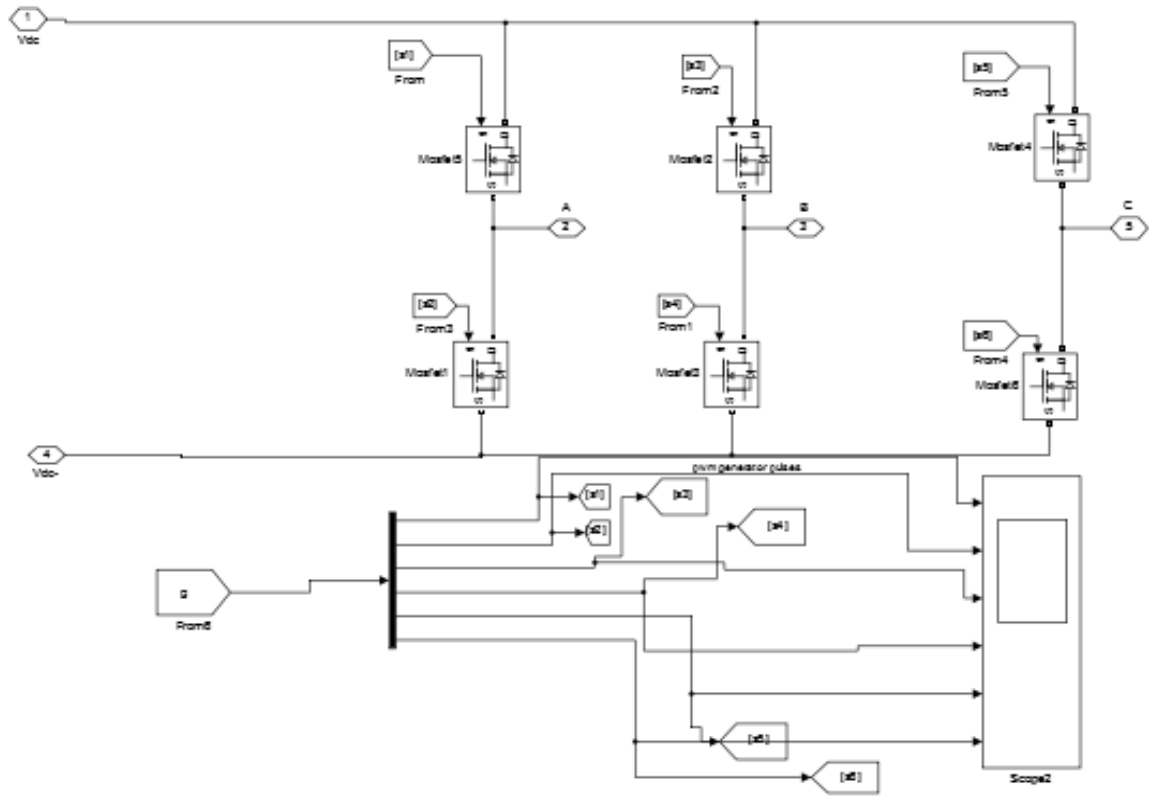

Fig.5 Simulink model of DC-AC Inverter

Inverter, it is a type of converter which convert the DC voltage/current into three phase AC voltage/current using switching devices like MOSFET, IGBT etc. There are two types of inverter current source inverter and voltage source inverter. In this paper we have used voltage source inverter which is fed from dc link capacitor which is connected in parallel with pv array. When an ideal switch is used as a switching device, the three level bridge block implements as an ideal switch with a three level topology. Current is being measured from each arm, the input is DC and output we get is in three phase AC form by using the switching devices. Phase to neutral voltage is measured and the DC voltage is measured across the terminal voltage of three level bridge block.

#### V. Controlling of Inverter from Grid

Here we have a simple way of modeling and the control strategy using dq0 transformation of a three-phase PWM inverter to be employed in a grid-connected photovoltaic generation system. The inverter used in this work is a three-phase bidirectional DC-AC converter with PWM modulation using six power switches.

The simplified diagram of the inverter is shown in Fig.6. The inverter modeling is quite simple and is completed through dq0 transformation which gives  $i_d$ ,  $v_d$ ,  $i_q$  and  $v_q$ . The modeling for the inverter control is obtained considering the AC output.

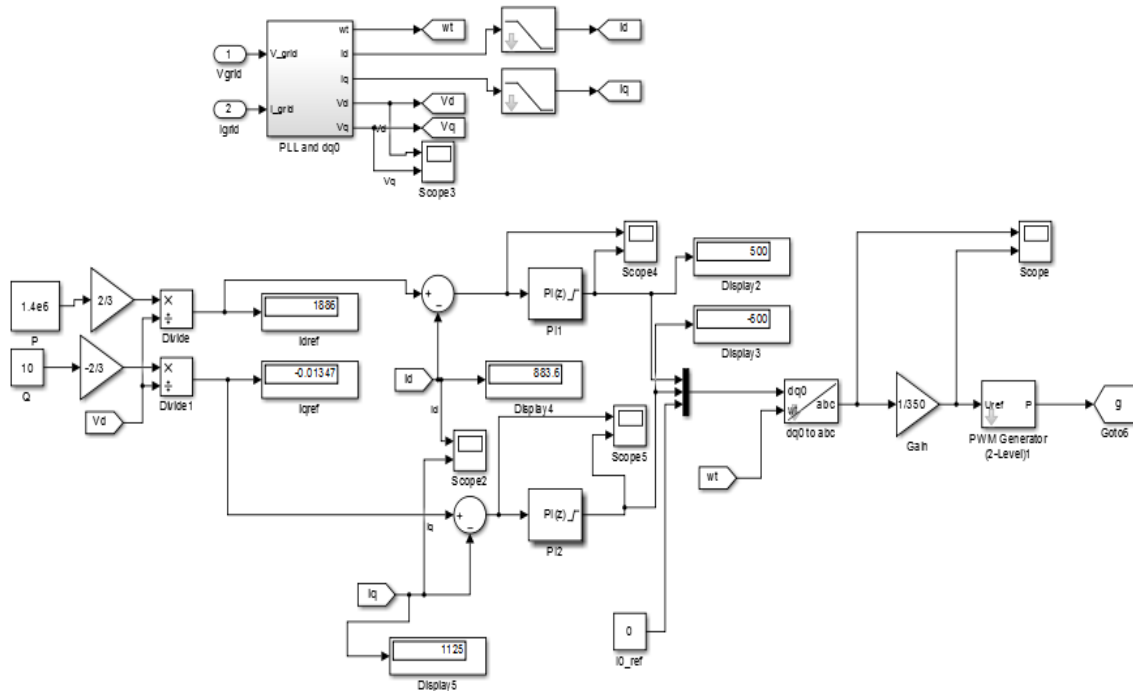

Fig.6 Control System of Inverter

The PLL i.e. phase locking loop is a very flexible circuit building block. Phase locking loop can be used for variety of applications such as radio frequency applications, from the frequency synthesizers to clock, FM demodulations etc. PLL is found in many radio frequency equipment and also in other items of radio frequency electronics. Keeping the input frequency and output frequency in lock step which also implies that to keep the input and output frequency same. In addition to the synchronizing signals, a PLL can track the input frequency or it generates a frequency which is the multiple of input frequency.

PLL is also used to demodulate the signal and to recover a signal from noisy communication channel and also to generate a stable frequency which is the multiple of input frequency i.e. frequency synthesis or to distribute precisely time clock pulses in digital logic circuits for example microprocessors.

The direct-quadrature-zero DQZ or DQ0 or DQO transformation or zero-direct-quadrature transformation is a tensor that rotates the reference frame of a three-element vector or a three-by-three element matrix in an effort to simplify analysis.

The transform can be used to rotate the reference frames of ac waveforms such that they become dc signals. Simplified calculations can then be carried out on these dc quantities before performing the inverse transform to recover the actual three-phase ac results.

The dq0 transform (often called the Park transform) is a space vector transformation of three-phase time-domain signals from a stationary phase coordinate system (ABC) to a rotating coordinate system (dq0).

We have transformed 3 variables  $i_a$ ,  $i_b$ , and  $i_c$  into two variables  $i_d$  and  $i_q$ , as we did in the  $\alpha$ - $\beta$  transformation. This yields an undetermined system, meaning

- We can uniquely transform  $i_a$ ,  $i_b$ , and  $i_c$  to  $i_d$  and  $i_q$
- We cannot uniquely transform  $i_d$  and  $i_q$  to  $i_a$ ,  $i_b$ , and  $i_c$ .

We will use as a third current the zero-sequence current:

$$I_0 = k_0 (i_a + i_b + i_c)$$

Choosing constants  $k_0$ ,  $k_q$ , and  $k_d$  to be  $1/3$ ,  $2/3$ , and  $2/3$ , respectively,

$$\begin{bmatrix} i_q \\ i_d \\ i_0 \end{bmatrix} = \frac{2}{3} \begin{bmatrix} \cos\theta & \cos(\theta-120) & \cos(\theta+120) \\ \sin\theta & \sin(\theta-120) & \sin(\theta+120) \\ \frac{1}{2} & \frac{1}{2} & \frac{1}{2} \end{bmatrix} \begin{bmatrix} i_a \\ i_b \\ i_c \end{bmatrix}$$

The inverse transformation becomes:

$$\begin{bmatrix} i_a \\ i_b \\ i_c \end{bmatrix} = \begin{bmatrix} \cos\theta & \sin\theta & 1 \\ \cos(\theta-120) & \sin(\theta-120) & 1 \\ \cos(\theta+120) & \sin(\theta+120) & 1 \end{bmatrix} \begin{bmatrix} i_q \\ i_d \\ i_0 \end{bmatrix}$$

## VI. Filter Circuit

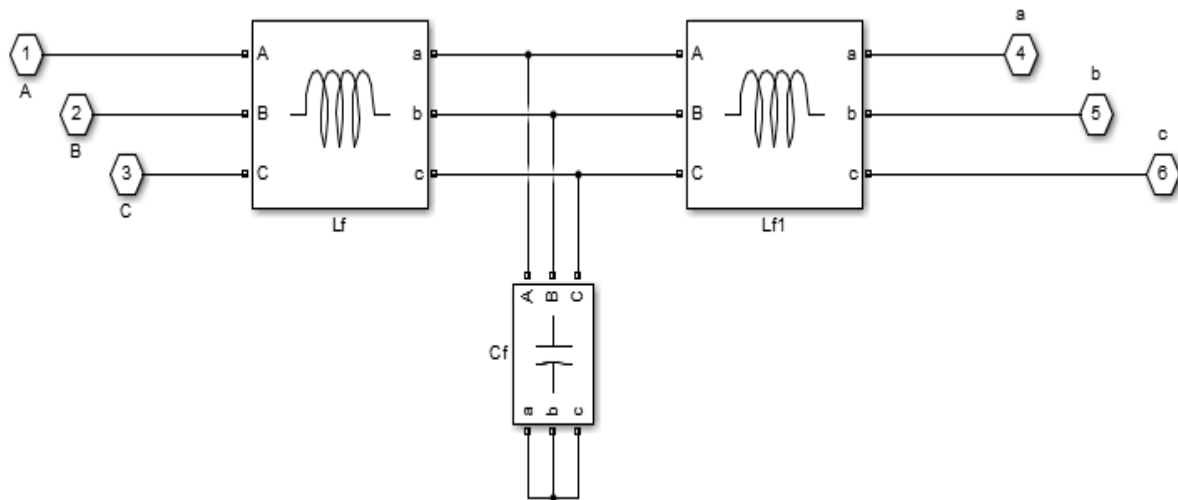

Fig.7 LCL Filter

Nominal frequency	50 Hz
Inductance	$2e^{-5}$
Capacitance	$1e^{-4}$

Table 1 Filter Parameters

Filter is a component that converts the variable AC voltage/current into constant AC voltage/current. It is a type of circuit consisting of an inductor and capacitor. This LC electric circuit is an idealized model since it assumes that due to resistance there is no energy dissipated. The purpose of this LC filter circuit is to oscillate with minimal damping, so the resistance is made as low as possible. Practically there is no ideal circuit.

Power electronics devices are used in this project, so it will lead to harmonics. To there is a need to remove this harmonic as to get smooth output waveforms and constant voltage without losses. So for harmonic compensation L-C filter is being used here, L-C filter will filter out the ripple current as well as harmonics and gives constant and smooth ac voltage and current.

### VII. Grid Connected Photovoltaic System

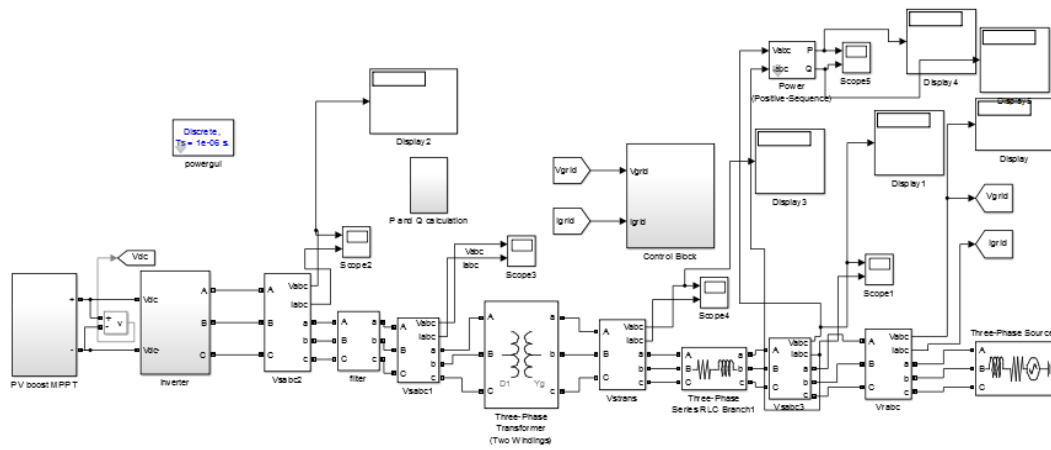

Fig .8 Grid Connected PV System

### VIII. Results

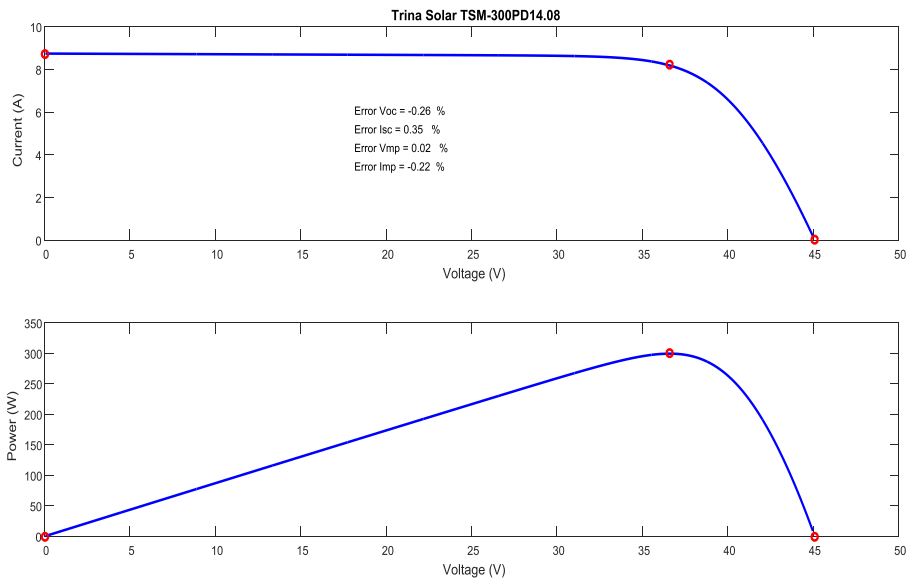

Fig.9 I-V and P-V curve of PV array

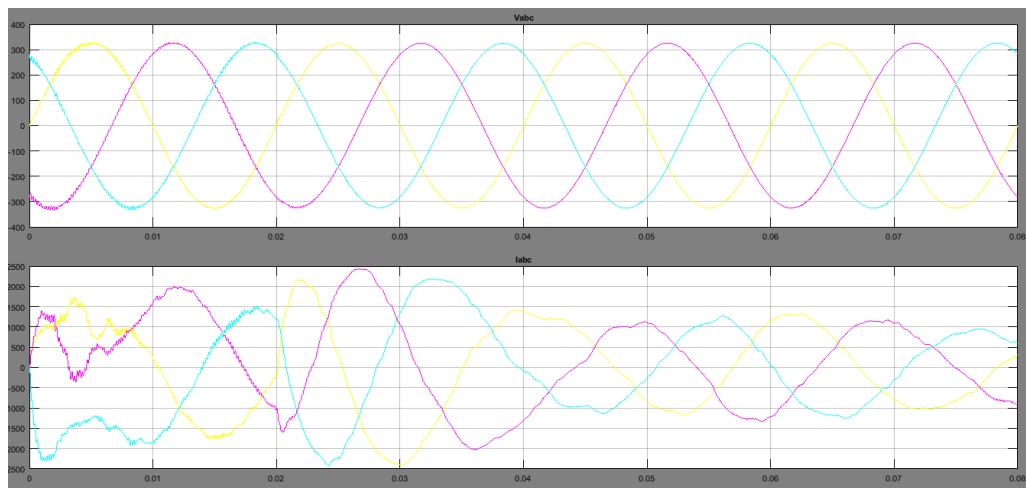

Fig.10 Inverter output

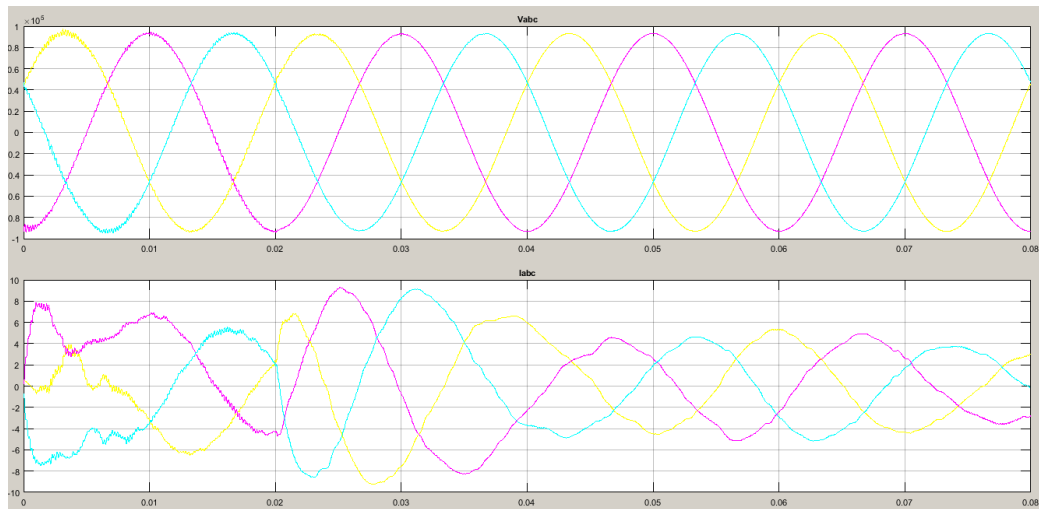

Fig.11 Output of V and I at Grid Side

### IX. Conclusion

In this project of modeling and control of grid integrated pv generate system. Models of solar pv module is modelled. The model for pv module is modeled in matlab/Simulink. As this modeled pv module have some limitations, the power generated by the module is used to compensate its own losses. DC-DC boost converter, DC-AC voltage source inverter, L-C filter are modeled in matlab/Simulink. Delta star step up transformer is the PCCpoint which couples pv source to the electric grid. Perturb and observe technique is the mppt technique used to extract maximum power from pv source. Dqo transformation , PLL used for synchronization of pv source to the grid and is employed in VSI inverter. Active and reactive power calculations are done to compensate reactive power due to the load. The complete modeling is done in matlab/Simulink.

### REFERENCES

1. N. Pandiarajan and Ranganath Muthu “Mathematical Modeling of Photovoltaic Module with Simulink” Department of Electrical & Electronics Engineering SSN College of Engineering Kalavakkam -603110, TamilNadu, India.
2. Zameer Ahmad, S.N. Singh “Modeling and Control of Grid Connected Photovoltaic System- A Review” International Journal of Emerging Technology and Advanced Engineering Volume 3, Issue 3, March 2013
3. N. Hamrouni\* and A. Chérif “Modelling and control of a grid connected photovoltaic system”Electrical Systems Laboratory, OS2E, High Engineering Academy of Tunis, PB 37, 1002 Le Belvedere, Tunis, Tunisia.
4. Consalva J. Msigwa, Beda J. Kundy and Bakari M.M. Mwinyiwiwa “ Control Algorithm for Shunt Active Power Filter using Synchronous Reference Frame Theory ” World Academy of Science, Engineering and Technology International Journal of Electrical, Computer, Energetic, Electronic and Communication Engineering.
5. Schonardie, Mateus F., Roberto F. Coelho, Rômulo Schweitzer, and Denizar C. Martins. "Control of the active and reactive power using dq0 transformation in a three-phase grid-connected PV system." In Industrial Electronics (ISIE), 2012 IEEE International Symposium on, pp. 264-269.