

**Women's security system with auto mail with images and instant location**Priyanka Choramale¹, Priyanka Gardade², Shubhangi Jadhav³, Prof. G.D.Salunke⁴¹Dept. of electronics and telecommunication Engg, AISSMS IOIT Pune.²Dept. of electronics and telecommunication Engg, AISSMS IOIT Pune.³Dept. of electronics and telecommunication Engg, AISSMS IOIT Pune.⁴Dept. of electronics and telecommunication Engg, AISSMS IOIT Pune.

Abstract — *The status of women in India has gone through many great changes over the past few millennia. From equal status with men in ancient times through the low points of the medieval period to the promotion of equal rights by many reformers, the history of women in India has been eventful. However, women in India continue to face social challenges and are often victims of abuse and violent crimes and, according to a global poll conducted by Thomson Reuters, India is the “fourth most dangerous country” in the world for women, and the worst country for women among the G20 countries. This paper focuses on a security system that is designed solely to serve the purpose of providing security to women so that they never feel helpless while facing such social challenges. This paper presents an analysis review on the principal need of intelligence security system with technology requirement and challenges to build the system. Since the prediction of such incident is not possible hence to minimize the possibility of physical violence (robbery, sexual assault etc.) by keeping all the help tools ready to safely escape from violent situation. This reduces risk and brings assistance when needed.*

Keywords- Women security, raspberry pi, GSM, GPS, camera etc.

I. INTRODUCTION

India which sees itself as a promising super power and an economic hub can achieve its goal if and only if a large numbers of women participate in the development process. This paper presents an analysis review on the principal need of intelligence security system with technology requirement and challenges to build the system. Since the prediction of such incident is not possible hence to minimize the possibility of physical violence (robbery, sexual assault etc.) by keeping all the help tools ready to safely escape from violent situation. This reduces risk and brings assistance when needed. The security system for women which allows immediate response in case of any harassment and mainly focuses on two different parts, one is surveying the recently developed mobile applications for women safety and protection. Radio frequency identification as the name implies use of radio frequencies to transfer data in a wireless non contact style to identify and track the tags that are attached to object. The tags contain electronically stored information. Tags can be powered in many ways. Some tags are powered by magnetic fields (electromagnetic induction)

Transportation facilities for these companies require huge amount of workload and complex infrastructure. Generally most of companies prefer local transport vendors on a yearly contract basis for the transportation of employees. But this is not the proper solution to the transportation and safety problem. Due to recently happened mishaps such as robbery and rape cases security for the women employees, has become number one priority for most of the companies. Most of the companies have security systems for employees but there are some serious drawbacks with those system as company cannot trust the drivers of transportation vehicles, cost of system. In order to deal with such security problems, the system is proposed with innovative solution. This system will help to track the location of vehicle through using smart GPS Device.

PROBLEM STATEMENT

In recent time its been identified lots of misbehaving activity in urban and rural part of our country. Rapes are not new in India. With some statistics citing the occurrence of one rape incident every 20 minutes, it is evident that it has reached epic proportions. Since mobility growth is been identified in recent 10 years and Smartphone penetration started 5 years ago. With the rapid growth of Android user and cheaper internet cost we can provide a simple medium to create safety awareness among the working and professional women of young and teen age.

II. LITERATUREREVIEW

1. Automated security system using surveillance AUTHOR: -P.Vigneswari et.al.

The world is experiencing a vast implementation of home security. And automation plays a vital role in the day to day life. The aim of this paper is to provide high level security and automation of appliances. This paper “Automated security system using surveillance” uses raspberry pi board which itself acts as a mini computer. Whenever a person enters into the room, the fans and light will automatically switch on. At the same time camera is also switched on and it takes the image of the person who has interrupted. The user is alerted by sending an SMS with the link using GSM modem. The image can be viewed by clicking on this link. In the absence of a person the fans and lights will automatically be switched off.

2. Smart girls security system AUTHOR:-Prof. Basavaraj Chougula et.al.

Today in the current global scenario, the prime question in every girl’s mind, taking into account the ever rising increase of issues on women harassment in recent past, is only about her safety and security. The only thought haunting every girl is when they will be able to move freely on the streets even in odd hours without worrying about their security. This paper suggests a new perspective to use technology to protect women. The system resembles a normal belt which when activated, tracks the location of the victim using GPS (Global Positioning System) and sends emergency messages using GSM (Global System for Mobile communication), to three emergency contacts and the police control room.

3. All in one intelligent safety system for women security AUTHOR:-AbhijitParadkar et.al.

According to the reports of WHO, NCRB-social-government organization 35% Women all over the world are facing a lot of unethical physical harassment in public places such as railway-bus stands, foot paths etc. In this paper the authors have reviewed of various existing systems on women security. The authors have felt a need of advanced women security system to provides the safety measure in public places as well as travelling alone through public transports (school buses, company vehicle etc). This paper proposed a new model for the women security in public places which aims to provide the 100% safe environment.

4. Women security system Author :-ShaikMazharHussain

This article surveys about the security system for women which allows immediate response in case of any harassment and mainly focuses on two different parts, one is surveying the recently developed mobile applications for women safety and protection and secondly, the proposed work .The users can press a button that is located on watch with RFID technology that is, RFID tag is embedded in the watch or locket that contains information about unique ID and name. The RFID reader is embedded in mobile phone that receives radio waves and once the RFID tag is activated and emits radio waves, the RFID reader takes the information and triggers the mobile phone where the processor will perform the task and sends the messages to 4 or 5 predefined contacts in which one is for police women cell where they can get the information about location of the victim through GPS and message alert “HELP”.

III. SYSTEM ARCHITECTURE

EXISTING SYSTEM

The existing system Project of security application provides the user alert by calling manually in the smartphones, the user cannot transmit the data of their location immediately and cannot protect the devices as soon as possible . Drawbacks of Existing System The

Drawbacks of the system is when emergency situation occurs the user cannot protect the smartphones and they cannot track the phones if they lost it. The user cannot be set the alert function when they are in risk situation and immediately they cannot pass their location to friends and family members to intimate they are in risk. The internet cost is too high and time delay to find out the IMEI number of mobile to track it.

PROPOSED SYSTEM

Women Safety system offers the added protection of being track by relatives on different time interval and different location. The main objective of the system is to track the current location of the person which has an SECURITY SYSTEM by extracting the longitude and latitude of that target person. The primary objective of our system is to track the person and plot the location on real time system like Google map.

The proposed system should overcome all the disadvantages of the existing system. The existing system is not functioning well due to manual process. Thus the proposed system should minimize the manual efforts. In such a way

that it should pass their location immediately when emergency situation occurs and protect the Smartphone by not using it after the services started.

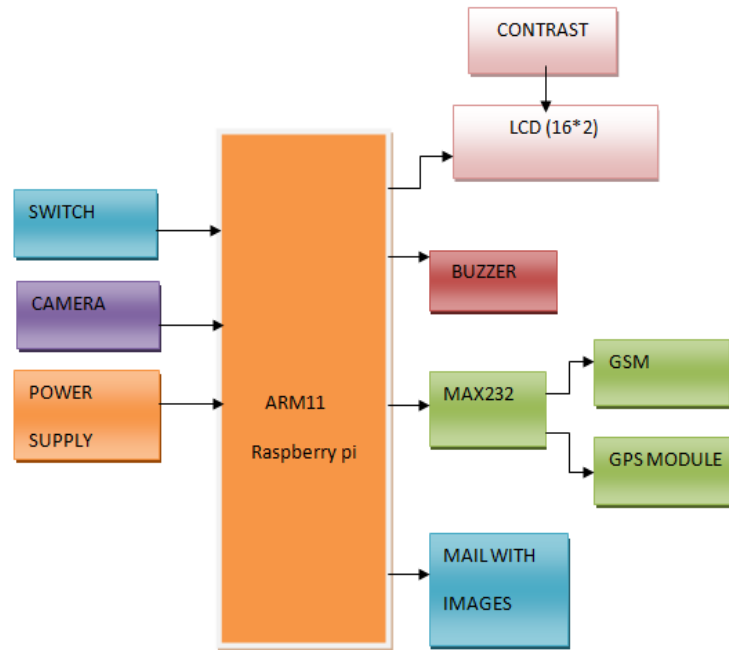

Fig. 1 Block diagram

This project is very useful for women security. This project uses keypad, GPS, GSM, Raspberry Pi, LCD. Raspberry Pi is the heart of this project. This project uses serial communication via RF. There are two sections one is transmitter & other one is receiver section. Transmitter section is consist switch. Receiver section consists of GPS, GSM & IOT other devices. In this project when women feel insecure, she press switch, at that time using GPS means global positioning system, position gets trace. That position will send to nearest police station /parents/friends/siblings. Along with message like help needed @ xxx position. When switch is press at that time camera also captures image and mail that image to nearest police station/parents/friends/sibling. We place display in our project, which always display all procedure happen around microprocessor unit.

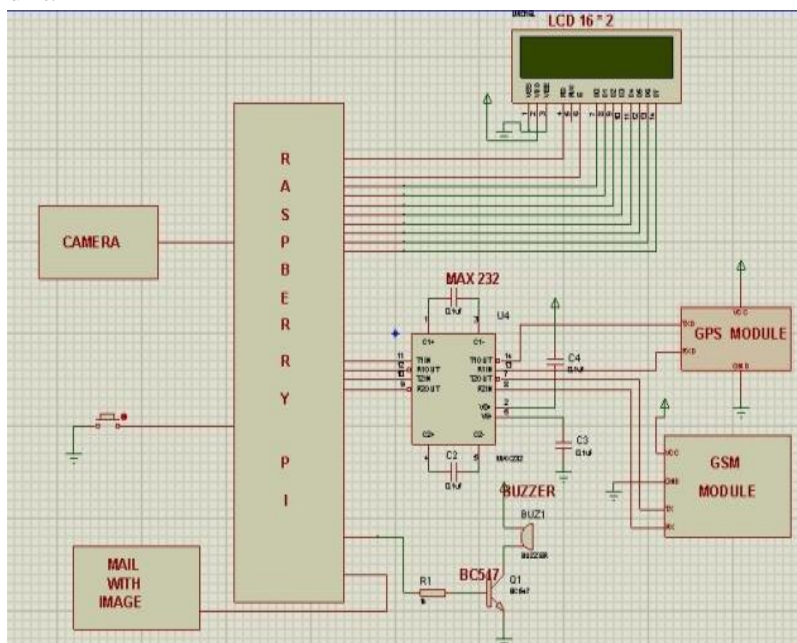

Fig. 2 Circuit diagram

METHODOLOGY

We track Girl /women who found in trouble , With help of module GPS ,GSM. When women feel her in danger then press button switch. Using camera we capture image & send that image through mail to respected person's parent /nearest Police station/ siblings . GSM and GPS modules get activate. GPS module trace location and give to the raspberry pi. Location send by GSM module to respected person also the captured image mail send to the related mail id we alert buzzer when women feel unsecure.

ALGORITHM

- STEP 1:- Power Up hardware.
- STEP 2:- Initialize hardware Module.
- STEP 3:-Display On LCD as "Women Security System"
- STEP 4:-When Switch is pressed, signal send to microcontroller..
- STEP 5:-Camera captures the image
- STEP 6:-IOT module mail that image.
- STEP 7:-GPS take the information of location
- STEP 8:-Location Send to GSM.
- STEP 9:- All info display on LCD

IV. COMPONENTS AND SYSTEM DESIGN:

1. Raspberry Pi Model

512 Mb with a nice black plastic case: The Raspberry Pi is a low cost, credit-card sized computer that plugs into a computer monitor or TV, and uses a standard keyboard and mouse. It has the ability to interact with the outside world, and has been used in real time applications. This board is the central module of the whole embedded image capturing and processing system as given in figure. Its main parts include: main processing chip, memory, power supply HDMI Out, Ethernet port, USB ports and abundant global interfaces.

2. USB camera

A webcam is a video camera that feeds or streams its image in real time to or through a computer to computer network. When "captured" by the computer, the video stream may be saved, viewed or sent on to other networks via systems such as the internet, and email as an attachment. When sent to a remote location, the video stream may be saved, viewed or on sent there. Unlike an IP camera (which connects using Ethernet or Wi-Fi), a webcam is generally connected by a USB cable, or similar cable, or built into computer hardware, such as laptops.

3. Liquid crystal display:

LCD stands for Liquid Crystal Display. LCD is finding wide spread use replacing LEDs (seven segment LEDs or other multi segment LEDs) because of the following reasons: The declining prices of LCDs. The ability to display numbers, characters and graphics. This is in contrast to LEDs, which are limited to numbers and a few characters. Incorporation of a refreshing controller into the LCD, thereby relieving the CPU of the task of refreshing the LCD. In contrast, the LED must be refreshed by the CPU to keep displaying the data.

4.Buzzer

The buzzer uses magnetism to make a loud sound. Electricity flows from the battery through the can and into the nail file. Every time the nail file hits the can, electricity flows through it to the electromagnet formed by the bolt and wire, through the switch, and back to the battery. The electromagnet pulls the file away from the can. As a result, the electricity stops, and the nail file springs back, striking the can again

and setting everything in motion once more. It's the movement of the electromagnet that makes the buzzing sound.

Specification

Voltage: 2 - 5VDC

Maximum current: 30mA/5VDC

Decibel: > 85db/10cm

Resonant frequency: 2500Hz (+/- 300 HZ)

Operating Temperature: -20 to 70 C

5. MAX 232

The is an integrated circuit first created in 1987 by Maxim Integrated Products that converts signals from a TIA-232 (RS-232) serial port to signals suitable for use in TTL compatible digital logic circuits. The MAX232 is a dual driver/receiver and typically converts the RX, TX, CTS and RTS signals. The MAX232 is an integrated circuit first created in 1987 by Maxim Integrated Products that converts signals from a TIA-232 (RS-232) serial port to signals suitable for use in TTL compatible digital logic circuits. The MAX232 is a dual driver/receiver and typically converts the RX, TX, CTS and RTS signals.

6. GSM module

This is a GSM/GPRS-compatible Quad-band cell phone, which works on a frequency of 850/900/1800/1900MHz and which can be used not only to access the Internet, but also for oral communication (provided that it is connected to a microphone and a small loud speaker) and for SMSs. Externally, it looks like a big package (0.94 inches x 0.94 inches x 0.12 inches) with L-shaped contacts on four sides so that they can be soldered both on the side and at the bottom.

7. GPS module

GPS Modem (Global Positioning System) for our esteemed customers. Their compact board size makes it easy to integrate them with handheld devices. Suitable for embedded applications, these modems have caught the attention of a large number of customers. Owing to their energy efficiency and immaculate design, these modems are highly appreciated by the customers.

V. ADVANTAGES AND APPLICATIONS

ADVANTAGES:

- Safety Device which can be carried by everyone
- Ultra low power consumption.
- Compact in size.
- Wireless connectivity.
- Easy and fast to install.

APPLICATIONS:

- Can be used for the safety of women.
- Can be used for the safety of children.
- Can be used for the safety of elderly aged people.
- Can be used for the safety of physically challenged people.

IV. CONCLUSION

The proposed design will deal with critical issues faced by women in the near past and will help to solve them with technologically sound equipments and ideas. This system can overcome the fear that scares every women in the country about her safety and security. The existing applications for women security and comes out with an innovative idea for security and protection for women and more research is possible with introducing IoT technology where people and objects form a network. Women's security is a critical and social issue in today's world. The crime against the women can be now brought to an end with the help of real system implementation of propose model.

The limitation of the devices can be overcome by storing the data onto the cloud. There is a need to make such systems standard and get approval from government, so that courts accept the evidences. We can also compact the system using advance chips so model comes at small size. It will easy to carry in purse and on hand, etc.

REFERENCES

- [1] Vigneswari, P., et al. "Automated Security System using Surveillance"." International journal of current engineering and technology 5.2 (2015): 882-884.
- [2] Chougula, Basavaraj, et al. "Smart girls security system." International Journal of Application or Innovation in Engineering & Management 3.4 (2014).
- [3] Paradkar, Abhijit, and Deepak Sharma. "All in one Intelligent Safety System for Women Security." International Journal of Computer Applications (0975–8887) Volume (2015).
- [4] ShaikMazharHussain. " Women Security System.", International Journal of Advanced Research in Computer Engineering & Technology (IJARCET) Volume 3 Issue 3, March 2014
- [5] Shruthi, G., et al. "Smart Safety Device for Security of Women." i-Manager's Journal on Embedded Systems 5.2 (2016): 1.
- [6] Shreyas, R. S., et al. "Design and Development of Women Self Defence Smart Watch Prototype." International Journal of Advanced Research in Electronics and Communication Engineering 5.4 (2016).